

INSTRUCTION MANUAL

Microcomputer Based Temperature Indicating Controller **ECS-200**

No.ECS21E3 2005.05

Thank you for the purchase of our Microcomputer based Temperature Indicating Controller ECS-200. This manual contains instructions for the mounting, functions and operations and notes when operating the ECS-200. For confirmation of the model and specifications of the unit, please read this instruction manual carefully before starting operation. To prevent accidents arising from the misuse of this controller, please ensure the operator receives this manual.

SAFETY PRECAUTIONS

- To ensure safe and correct use, thoroughly read and understand this manual before using this instrument.
- This instrument is intended to be used for industrial machinery, machine tools and measuring equipment. Verify correct usage after consulting purpose of use with our agency or main office. (Never use this instrument for medical purposes with which human lives are involved.)
- External protection devices such as protection equipment against excessive temperature rise, etc. must be installed, as malfunction of this product could result in serious damage to the system or injury to personnel. Also proper periodic maintenance is required.
- This instrument must be used under the conditions and environment described in this manual. Shinko Technos Co., Ltd. does not accept liability for any injury, loss of life or damage occurring due to the instrument being used under conditions not otherwise stated in this manual.

Caution with respect to Export Trade Control Ordinance

To avoid this instrument from being used as a component in, or as being utilized in the manufacture of weapons of mass destruction (i.e. military applications, military equipment, etc.), please investigate the end users and the final use of this instrument. In the case of resale, ensure that this instrument is not illegally exported.

Warning

Turn the power supply to the instrument OFF before wiring or checking.
Working or touching the terminal with the power switched on may result in severe injury or death due to Electric Shock.

1. Model name

1.1 Name

ECS - 2 <input type="checkbox"/> <input type="checkbox"/> - <input type="checkbox"/> / <input type="checkbox"/> <input type="checkbox"/> <input type="checkbox"/>		Series name: ECS-200 (W48 x H48 x D85mm)	
Control action	1		ON/OFF action
	2		PD action
Temperature alarm (ALM)	0		No alarm
	2		High limit alarm
	3		Low limit alarm
	4		High/Low limits alarm
	6		High/Low limit range alarm
	8		Process alarm
Control output (CON)	R		Relay contact: 1a
	S		Non-contact voltage (for SSR drive): 15±3V DC
Input	E		Thermocouple: K, J
	R		RTD: Pt100, JPt100
Option	H		Standby function applied *
	W(5A)	Heater burnout alarm	Rated current: 5A
	W(10A)		Rated current: 10A
	W(20A)		Rated current: 20A
	CM		Cooling action
	SB		Specified proportional band : 0.1 to 9.9%
	SK		Specified control sensitivity : 0.1 to 2.0%
	SC		Specified proportional cycle: 1 to 99 seconds
	BK		Color, Black
BL		Screw type mounting bracket	

* When High/Low limits alarm (ECS-214, ECS-224) is applied, the standby function activates only for Low limit alarm.

1.2 How to read the model name label

Model name label is attached to the case and inner assembly.

	[Model name label]	[Example]
(1)	ECS-224-R/E	Relay contact output/Thermocouple input
(2)	H	Standby function applied
	SC(30)	Specified proportional cycle (30s)
(3)	No.	

(1): Model name

(2): Option codes

(3): Serial number (Indicated only on the internal assembly)

For the Heater burnout alarm [HB], specified proportional band [SB], specified control sensitivity [SK] and specified proportional cycle [SC], the specified value is entered in the bracket ().

2. Name and functions of the sections

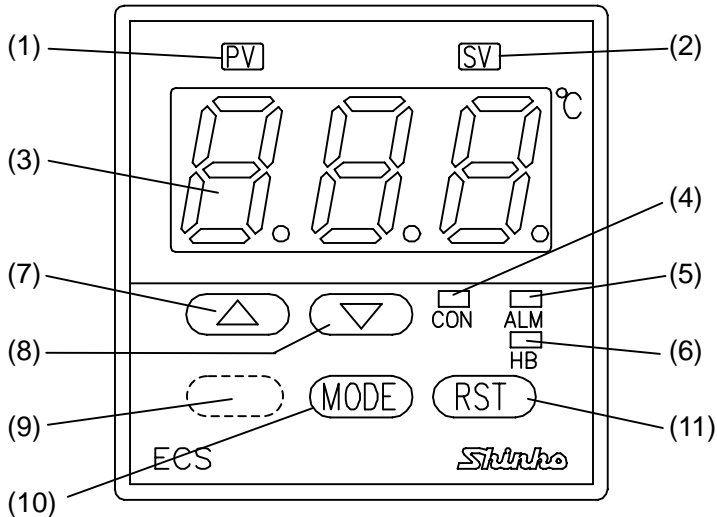

[Fig. 2-1]

- (1) PV indicator
When the digital display indicates the PV (process variable), a red LED is lit.
- (2) SV indicator
When the digital display indicates the SV (set value), a green LED is lit.
- (3) Digital display
Indicates the PV (process variable), SV (set value), setting characters with a red LED.
- (4) Control output indicator
When the control output is on, a green LED is lit.
- (5) Temperature alarm action indicator
When the temperature alarm output is on, a red LED is lit.
- (6) Heater burnout alarm, Sensor burnout alarm action indicator
When the Heater burnout alarm or Sensor burnout alarm is on, a red LED is lit.
- (7) Increase key
Increases the numeric value or selects the set value.
- (8) Decrease key
Decreases the numeric value or selects the set value.
- (9) Sub mode key
By pressing the Mode key while pressing the Sub mode key in the PV/SV display mode, the unit proceeds to the Auxiliary function setting mode.
- (10) Mode key
Selects the setting mode, or registers the set value and selected value.
- (11) Reset key
Performs the auto-reset (offset correction).

How to switch the PV or SV indication

Press the Increase key to indicate the PV, and the Decrease key to indicate the SV for approx. 10 seconds respectively.

How to register the set value

Press the Mode key to register the set value (numeric value).

When the key operation is stopped in the process of setting, the unit automatically reverts to the PV/SV display mode in approx. 30 seconds, and the value before the key operation was stopped is registered.

3 Settings

3.1 Operation flowchart

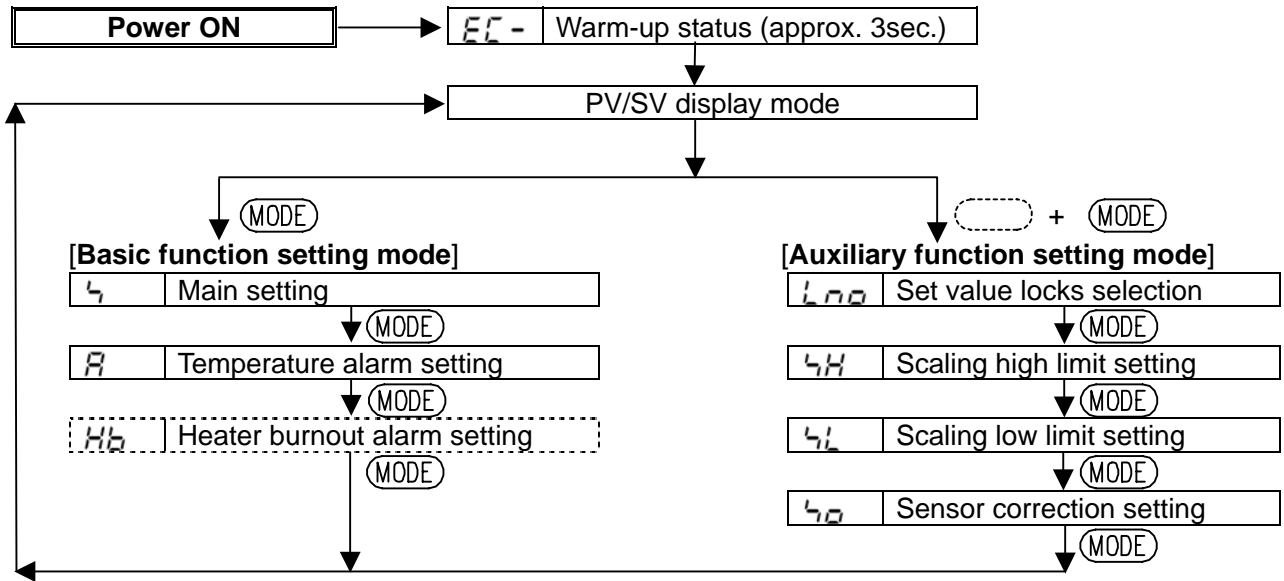

- The setting item with dotted lines is optional, and it appears only when the option is added.
- “Temperature alarm setting” is indicated only when the alarm function is added.

After the power is switched on, the Digital display indicates [EE -] for approx. 3 seconds during warm-up. During this time, all outputs and LED indicators are in OFF status. After that, the actual temperature (PV) or main set value (SV) is indicated on the Digital display, and the control starts.

⚠ Caution

During warm-up status (for approx. 3 seconds), do not operate any keys since the instrument specifications may be altered.

Do not turn the power supply ON during key operations.

3.2 PV/SV display mode

Control status such as PV or SV is indicated on the Digital display. The PV indicator is lit while the PV is indicated on the Digital display, and the SV indicator is lit while the SV is indicated on the display. Default value: PV indication

3.3 Basic function setting mode

Characters	Setting
4 ↔ 0 Indicates in turn.	Main setting <ul style="list-style-type: none"> • Sets the main set value. • Setting range: Main set value low limit to main set value high limit • Default value: 0°C
A ↔ 0 Indicates in turn.	Temperature alarm setting <ul style="list-style-type: none"> • Sets the action point of the temperature alarm. • Not available for the ECS-2□0 type which has no temperature alarm. • Off when set to 0 • However, for the RTD input and the process alarm is selected, the alarm activates even if the set point is set to “0”. • Setting range: Refer to (Table 3.3-1) on page 4. • Default value: 0°C

<p>Hb ↔ 0 Indicates in turn.</p>	<p>Heater burnout alarm setting</p> <ul style="list-style-type: none"> • Sets the heater current value. • Available only when the W option is applied. • The alarm output is maintained once the alarm activates. To release the alarm, turn the power supply to the unit OFF, then ON again. • Setting range: 0 to 100% • Default value: 0% <p>Formula of the action point (set value)</p> $Ap = \frac{Hc}{Rv} \times 100$ <p>Where Ap: Action point (set value) (%) Hc: Heater maximum current (A) Rv: Rated value (5A, 10A, 20A)</p> <p>It is recommended that the action point should be set around 80% of the action point considering the voltage fluctuation.</p>
---	---

(Table 3.3-1)

Alarm type	Setting range
High limit alarm	-100 to 100°C
Low limit alarm	-100 to 100°C
High/low limits alarm	±(1 to 100)°C
High/low limit range alarm	±(1 to 100)°C
Process alarm	Scaling low limit to scaling high limit

3.4 Auxiliary function setting mode

Characters	Set value locks selection
Lno	<ul style="list-style-type: none"> • Locks the set value to protect setting errors. • Loc (Lock) : None of set values can be changed. • Lno (Unlock) : All set values can be changed.
4H ↔ Specified rated value Indicated in turn.	<p>Scaling high limit setting</p> <ul style="list-style-type: none"> • Sets the Scaling high limit value of the scale. (Scaling high limit value depends on the sensor type.) • Setting range: Refer to (Table 3.4-1). • Default value: Specified rated value
4L ↔ Specified rated value Indicated in turn.	<p>Scaling low limit setting</p> <ul style="list-style-type: none"> • Sets the Scaling low limit value of the scale. (Scaling low limit value depends on the sensor type.) • Setting range: Refer to (Table 3.4-1). • Default value: Specified rated value
4o ↔ 0 Indicated in turn.	<p>Sensor correction setting</p> <ul style="list-style-type: none"> • Sets the sensor correcting value. • Setting range: -30 to 30°C • Default value: 0°C

Sensor correction function

This corrects the input value from the sensor. When a sensor cannot be set at the exact location where control is desired, the sensor measured temperature may deviate from the temperature in the controlled location.

When controlling with plural controllers, sometimes the measured temperatures (input value) do not concur with the same setting value due to difference in sensor accuracy or dispersion of load capacities. In such a case, the control can be set at the desired temperature by adjusting the input value of sensors.

(Table 3.4-1)

Sensor type	Setting range	Minimum scale span accuracy guaranteed
K	0 to 300°C	300°C
	0 to 400°C	
	0 to 600°C	
	0 to 800°C	
	0 to 999°C	
J	0 to 300°C	
	0 to 400°C	
	0 to 600°C	
	0 to 800°C	
Pt100 JPt100	0 to 200°C	200°C
	-100 to 300°C	

If the scale range is set narrower than the minimum scale span accuracy guaranteed, the accuracy is not guaranteed.

4. Operation

After the unit is mounted to the control panel and wiring is completed, operate the unit following the procedures below.

(1) Turn the power supply to the ECS-200 ON.

After the power is switched on, the Digital display indicates [$\bar{E} \bar{L} -$] for approx. 3 seconds during warm-up.

During this time, all outputs and LED indicators are in OFF status.

After that, the actual temperature (PV) or main set value (SV) is indicated on the Digital display, and control starts.



Caution

During the warm-up status (for approx. 3 seconds), do not operate any keys since the instrument specifications may be altered.

Do not turn the power supply ON during key operation.

(2) Input the set value.

Input each set value, referring to Chapter "3. Settings".

(3) Turn the load circuit power ON.

Control action starts so as to keep the control target at the main set value.

5. Other functions

(1) Operational error protection function

If a key operation has not been performed for approx. 30 seconds during the Basic function setting mode or Auxiliary function setting mode, the controller automatically switches to the PV/SV display mode, and the set value is registered.

(2) Sensor burnout alarm (Burnout, upscale)

If the thermocouple is burnt out, the control output is turned OFF and the Sensor burnout alarm action indicator lights. At this time, if the PV is indicated on the Digital display, [$\bar{ } \bar{ } \bar{ }$] flashes.

(Once the alarm activates, the output is held until the power to the instrument is switched OFF.)

When the PV exceeds 999°C of "K" input, 900°C of "J" input, 350°C of Pt100 input, the same action occurs as the above.

(3) Self-diagnosis

The CPU is monitored by a watchdog timer, and when any abnormal status is found on the CPU, the controller is switched to warm-up status.

(4) Automatic cold junction temperature compensation (only for thermocouple input)

This detects the temperature at the connecting terminals between the thermocouple and the instrument, and always maintains the same status as when the reference junction is located at 0°C (32°F).

6. Action explanations

6.1 Proportional action

	Heating (reverse) action	Cooling (direct) action (Option: CM)
Control action		
Relay contact output	<p>Cycle action according to deviation</p>	<p>Cycle action according to deviation</p>
Non-contact voltage output	<p>Cycle action according to deviation</p>	<p>Cycle action according to deviation</p>
Indicator (CON) Green		

: Acts ON or OFF.

6.2 ON/OFF action

	Heating (reverse) action	Cooling (direct) action [Option: CM]
Control action		
Relay contact output		
Non-contact voltage output		
Indicator (CON) Green		

* : Control sensitivity

6.3 Heater burnout alarm action

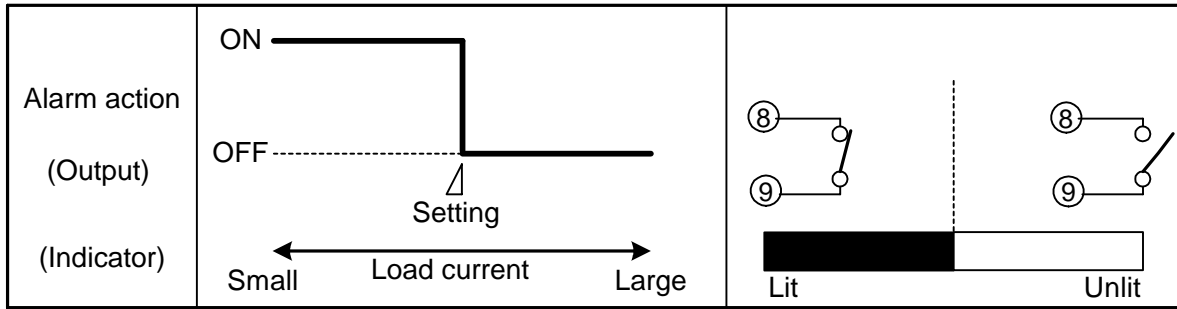

6.4 Temperature alarm action

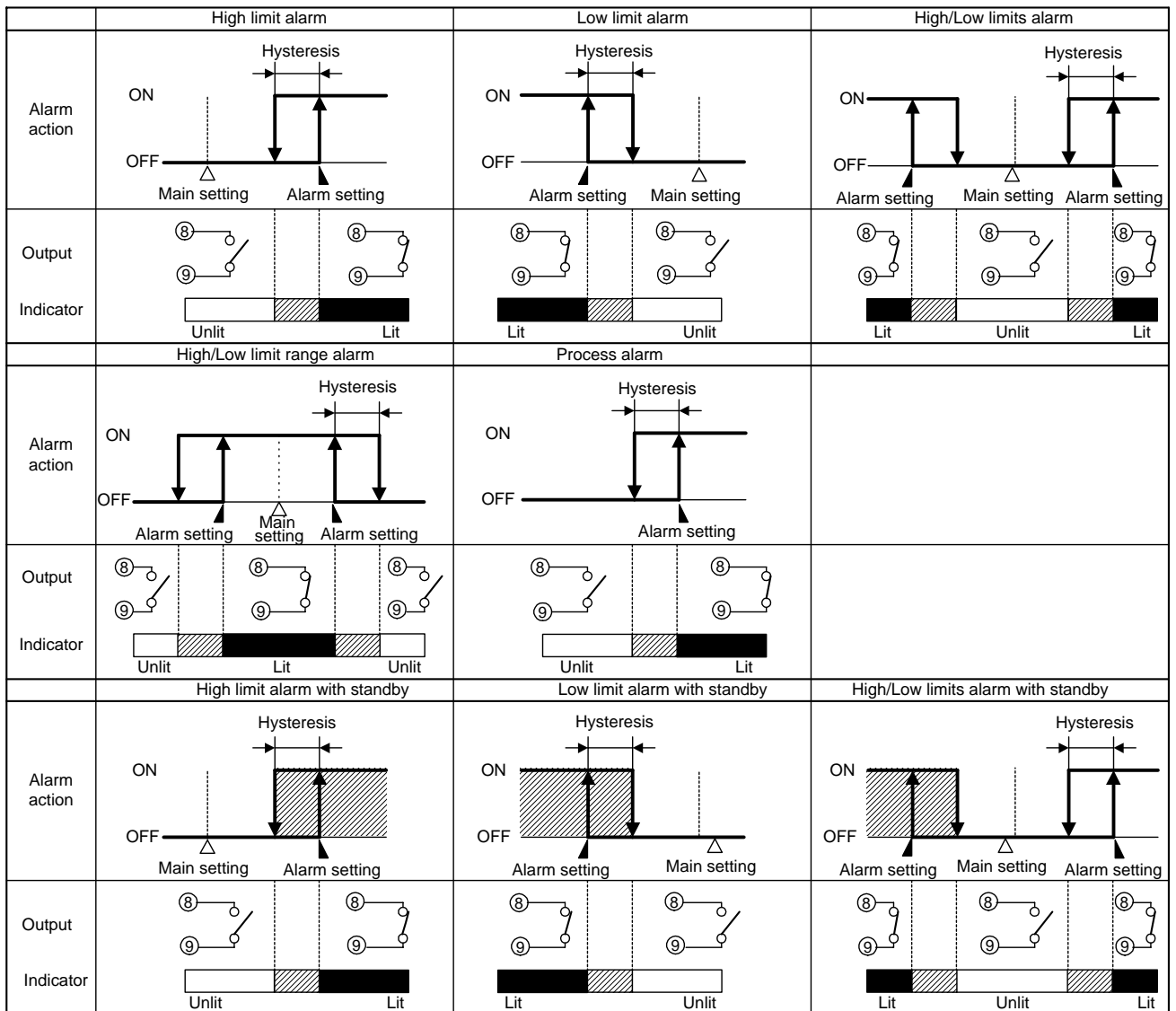

6.5 Auto-reset (offset correction)

Auto-reset is performed to correct the offset at the point at which PV indication is stabilized within the proportional band during the PD action.

Since the corrected value is internally memorized, it is not necessary to perform the auto-reset again as long as the process is the same.

- Auto-reset does not work in the ON/OFF control action mode.
- Make sure to press the **(RST)** key just once.

If the **(RST)** key is pressed twice or more, the offset will not be corrected normally.

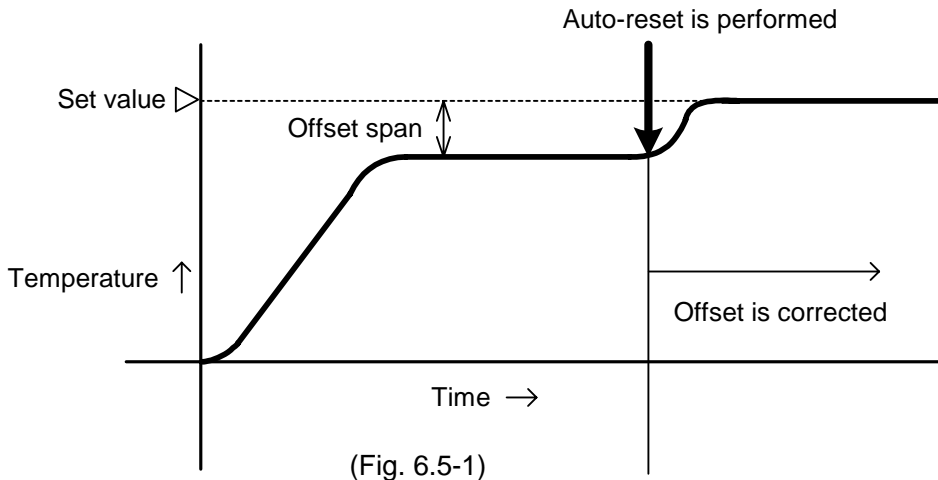

7. Mounting to the control panel

7.1 Site selection

Ensure the mounting location corresponds to the following conditions:

- A minimum of dust, and an absence of corrosive gasses
- No flammable, explosive gasses
- No mechanical vibrations or shocks
- No exposure to direct sunlight, an ambient temperature of 0 to 55°C (32 to 131°F) that does not change rapidly
- An ambient non-condensing humidity of 35 to 85%RH
- No large capacity electromagnetic switches or cables through which large current is flowing
- No water, oil or chemicals or where the vapors of these substances can come into direct contact with the unit

7.2 External dimension (Unit: mm)

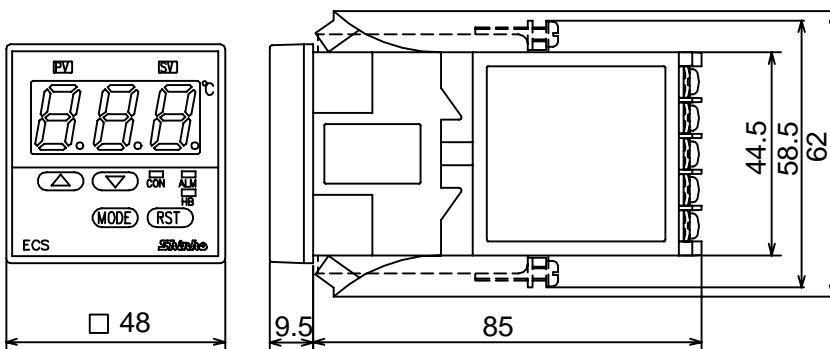

7.4 CT dimensions (Unit: mm)

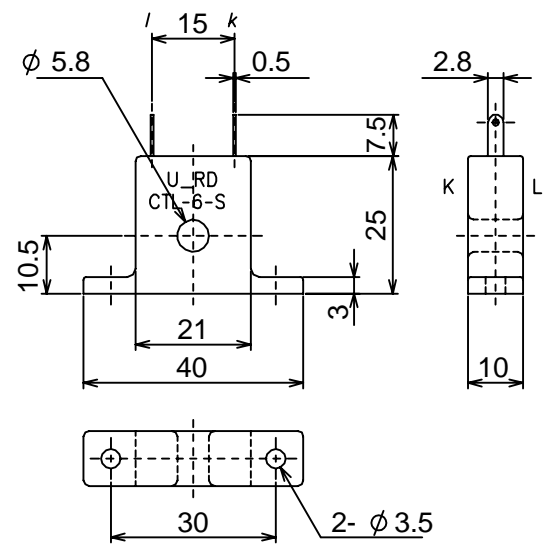

7.3 Panel cutout (Unit: mm)

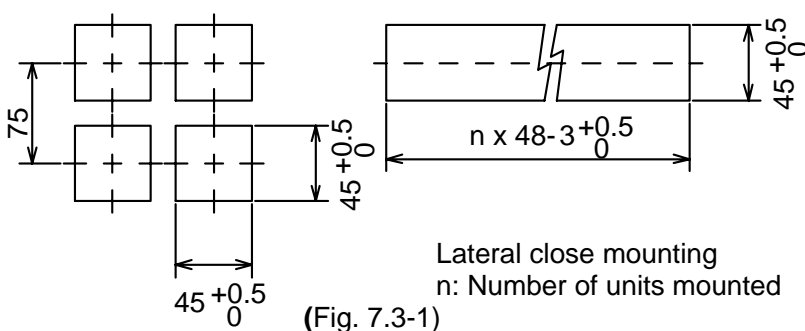

7.5 Mounting

[When using screw type mounting bracket]

Mounting panel thickness is within 1 to 8mm.
 Insert the unit from the front of the control panel.
 Slot the mounting bracket to the holes at the top and bottom of the case, and fasten with screws.
 When using the soft front cover (FC-48-S), the panel thickness is within 1 to 7.5mm.

[When using one-touch type mounting bracket]

Mounting panel thickness is within 1 to 3mm.
 First, mount the one-touch type mounting bracket at the top and bottom of the controller.
 Then insert the controller from the front of the panel.
 When using the soft front cover (FC-48-S), the panel thickness is within 1 to 2.5mm.



Notice

As the case is made of resin, do not use excessive force while screwing in the mounting bracket, or the case could be damaged.

The torque is approximately 0.4N•m.

8. Wiring



Warning

Turn the power supply to the instrument OFF before wiring or checking.

Working or touching the terminal with the power switched on may result in severe injury or death due to Electric Shock.

8.1 Terminal arrangement

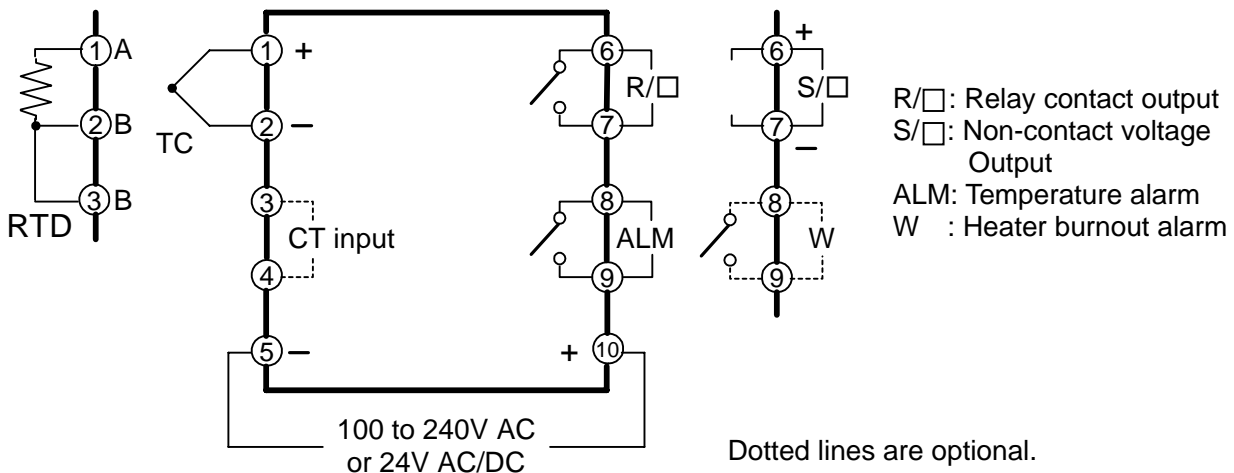

(Fig. 8.1-1)



Caution

- The terminal block of the ECS-200 is designed to be wired from the left side. The lead wire must be inserted from the left side of the terminal, and tightened with the terminal screw.
- Use a thermocouple and compensating lead wire according to the sensor input specifications of this controller.
- Use the 3-wire RTD which corresponds to the input specifications of this controller.
- This controller does not have built-in power switch or fuse. Therefore it is necessary to install them in the circuit near the external controller.
- 24V AC or DC is usable as a power source, however, do not confuse polarity when using direct current (DC).
- When using a relay contact output type, externally use a relay according to the capacity of the load to protect the built-in relay contact.
- When wiring, keep input wires (Thermocouple, RTD, etc.) away from AC sources or load wires to avoid external interference.

● **Recommended terminal**

Use a solderless terminal with an insulation sleeve in which an M3 screw fits as shown below. The tightening torque is 0.6N•m to 1.0N•m.

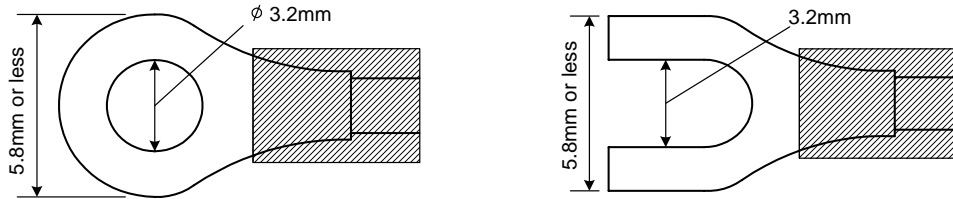

(Fig. 8.1-2)

Solderless terminal	Manufacturer	Model name	Tightening torque
Y type	Nichifu Terminal Industries CO., LTD.	1.25Y-3	0.6N•m Max. 1.0N•m
	Japan Solderless Terminal MFG CO., LTD.	VD1.25-B3A	
Round type	Nichifu Terminal Industries CO., LTD.	1.25-3	
	Japan Solderless Terminal MFG CO., LTD.	V1.25-3	

● **Option: Heater burnout alarm output**

- (1) This alarm is not usable for detecting current under phase control.
- (2) Use the current transformer (CT) provided, and pass one lead wire of heater circuit into a hole of the CT.
- (3) When wiring, keep the CT wire away from any AC sources and load wires to avoid the external interference.

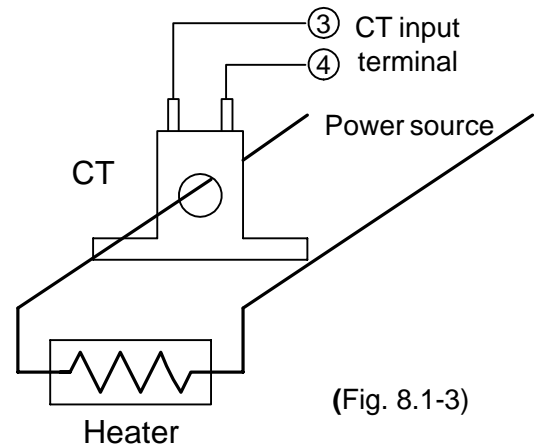

(Fig. 8.1-3)

8.2 Wiring example

ECS-222-R/E

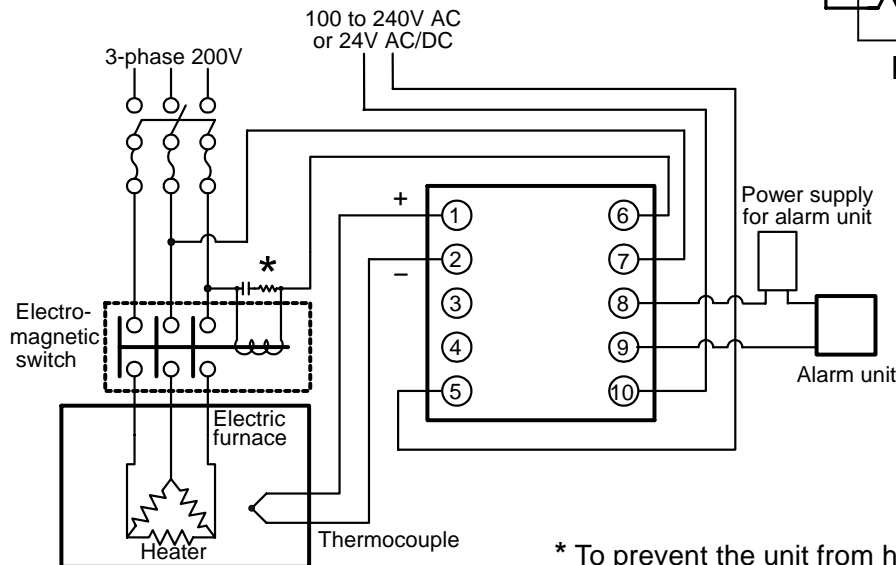

(Fig. 8.2-1)

* To prevent the unit from harmful effects of unexpected level noise, it is recommended that a surge absorber be installed between the electro-magnetic switch coils.

- The connectable SSRs in parallel are 4 units if the Shinko SSRs (SA-200 series) are used.
- 24V AC or DC is usable for the power supply, however, do not confuse polarity when using direct current (DC).

9. Specifications

9.1 Standard specifications

- Mounting method** : Flush
- Setting** : Input system using membrane sheet key
- Display** : PV/SV display, Red LED display 3 digits, size 8 x 14.3mm (W x H)
- Accuracy (Setting, Indication):**

Within $\pm 0.5\%$ of input span ± 1 digit

However, scale span 300°C or more for TC and 200°C or more for RTD

- Input** Thermocouple : K, J External resistance, 100Ω or less
 RTD : Pt100, JPt100, 3-wire system
 Allowable input lead wire resistance (10Ω or less per wire)
- Control output**
 Relay contact : 1a, Control capacity, 3A 220V AC (resistive load)
 1A 220V AC (inductive load cosφ=0.4)
 Electric life, 100,000 times
 Non-contact voltage (for SSR drive):
 15±3V DC (load resistance 1.5kΩ) 20mA DC (short circuit protected)
- Temperature alarm output:**
 Action : ON/OFF action, Hysteresis, 1°C
 Output : Relay contact, 1a
 Control capacity : 3A 220V AC (resistive load)
 1A 220V AC (inductive load cosφ=0.4)
 Electric life : 100,000 times
- Control action**
 PD action Proportional band : 2.5% of the scaling span
 Derivative time : 32seconds
 Proportional cycle : 20sec. (for relay contact output type)
 3sec. (for non-contact voltage output type)
 ON/OFF action Control sensitivity : 0.3% of the scaling span (Hysteresis: 0.6%)
- Insulation resistance** : 10MΩ or more, at 500V DC
 Between input terminal and grounding, Between input terminal and power terminal
 Between output terminal and grounding, Between output terminal and power terminal
 Between power terminal and grounding
- Dielectric strength** : 1.5kV AC for 1 minute
 Between input terminal and grounding, Between input terminal and power terminal
 Between output terminal and grounding, Between output terminal and power terminal
 Between power terminal and grounding
- Supply voltage** : 100 to 240V AC, 50/60Hz 24V AC/DC, 50/60Hz
- Allowable voltage fluctuation:**
 In the case of 100 to 240V AC: 85 to 264V AC
 In the case of 24V AC/DC: 20 to 28V AC/DC
- Power consumption** : Approx. 5VA
Ambient temperature: 0 to 55°C (32 to 131°F)
Ambient humidity : 35 to 85%RH (non-condensing)
Weight : Approx. 150g
External dimension : 48 x 48 x 85mm (W x H x D)
Material : Case, Polycarbonate resin
Color : Case, Light gray
Attached functions : Scaling, Sensor correction, Set value Locks, Power failure countermeasure,
 Self-diagnostic function, Automatic cold junction temperature compensation,
 Sensor burnout alarm
- Accessories** : One-touch type mounting bracket 1 set
 Screw type mounting bracket 1 set (When the BL option is applied.)
 Instruction manual 1 copy
 Terminal cover 1 piece (When the TC option is applied.)
 CT (Current transformer, CTL-6-S) 1 piece (When the W option is applied.)

9.2 Optional specifications

Temperature alarm with standby function (option code: H)

After the power supply to the instrument is turned on, even if the input enters the alarm action range, the alarm is not activated.

Even if the alarm action point enters the alarm action range due to the SV being changed while the controller is running, the alarm is not activated, either.

This function can be applied to the High limit, Low limit and High/Low limits alarm.

However, for ECS-214 and ECS-224 types, standby function works only for Low limit alarm.

Heater burnout alarm output (option code: W)

Monitors heater current with CT (current transformer), and detects the burnout.

Rating : 5A [W (5A)], 10A [W (10A)], 20A [W (20A)] (Must be specified)

Setting range : 0 to 100%

Setting accuracy : ±5% of rated value

Action : ON/OFF action
 Output : Relay contact 1a Control capacity, 3A 220V AC (resistive load)
 1A 220V AC (inductive load, $\cos\phi=0.4$)
 Electric life: 100,000 times

Cooling action (option code: CM)

Cooling action (Direct action): Control action

PD action Proportional band : 2.5% of the scaling span
 Derivative time : 32 seconds
 Proportional cycle : 20sec. (for relay contact output type)
 3sec. (for non-contact voltage output type)

ON/OFF action Control sensitivity, 0.3% of the scaling span (Hysteresis: 0.6%)

Specified proportional band (option code: SB) Setting range: 0.1 to 9.9% of the scaling range

Specified control sensitivity (option code: SK) Setting range: 0.1 to 2.0% of the scaling range



Specified proportional cycle (option code: SC) Setting range: 1 to 99 seconds

Color, Black (option code: BK) Panel: Dark gray Base, case: Black

Screw type mounting bracket (option code: BL) Panel thickness: Within 1 to 8mm

10. Troubleshooting

If any malfunctions occur, refer to the following items after checking the power and the wiring.

Problem	Presumed cause and solution
[- - -] is flashing on the Digital display.	<ul style="list-style-type: none"> • Thermocouple or RTD is burnt out. [Thermocouple] If the input terminal of the instrument is shorted, and if a value around room temperature is indicated, the instrument is likely to be operating normally, however, the sensor may be burnt out. [RTD] If approx. 100Ω of resistance is connected to the input terminals between A-B of the instrument and between B-B is shorted, and if approximate 0°C (32°F) is indicated, the instrument is likely to be operating normally, however, the sensor may be burnt out. • Check whether the input terminals of thermocouple or RTD are securely mounted to the instrument input terminals.
The indication of PV is abnormal or unstable.	<ul style="list-style-type: none"> • Sensor correcting value is unsuitable. Set it to a suitable value. • Check whether the specification of the sensor is correct. • AC leaks into the sensor circuit. • There may be equipment that interferes with or makes noise near the controller. Keep equipment that interferes with or makes noise away from the controller.
Temperature does not rise.	<ul style="list-style-type: none"> • Thermocouple or RTD is burnt out. Replace the sensor. • Check whether the Sensor terminals are securely mounted to the instrument input terminals. Ensure that the sensor terminals are mounted to the instrument input terminals securely. • Check whether the wiring of sensor or control output terminals is correct.
The main set value does not change by the  and  keys and new values are unable to be set.	<ul style="list-style-type: none"> • Scaling high limit or low limit value may be set at the point where the value does not change. Set it to a suitable value while in the Auxiliary function setting mode. • Set value locks is selected.

For all other malfunctions, please contact our main office or dealers.

SHINKO TECHNOS CO.,LTD. OVERSEAS DIVISION

Reg. Office : 2-48, 1-Chome, Ina, Minoo, Osaka, Japan

Mail Address : P.O.Box 17, Minoo, Osaka, Japan

URL : <http://www.shinko-technos.co.jp>

E-mail : overseas@shinko-technos.co.jp

Tel : 81-72-721-2781

Fax: 81-72-724-1760