

DIGITAL INDICATING CONTROLLER

JCM-33A

INSTRUCTION MANUAL

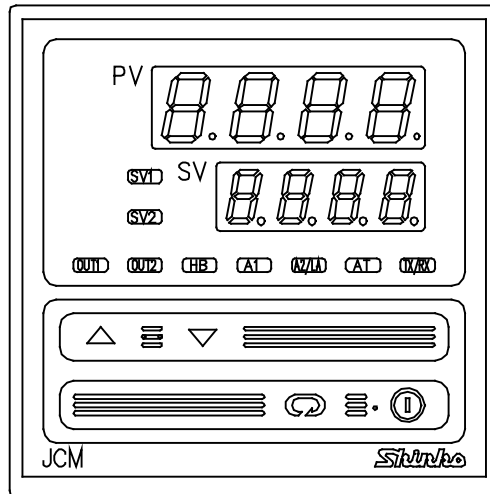

Shinko

Preface

Thank you for purchasing our Digital Indicating Controller JCM-33A.

This manual contains instructions for the mounting, functions, operations and notes when operating the JCM-33A.

For model confirmation and unit specifications, please read this manual carefully before starting operation.

To prevent accidents arising from the misuse of this controller, please ensure the operator receives this manual.

Abbreviations Used in This Manual

Symbol	Term
PV	Process variable
SV	Desired value
MV	Output manipulated variable
OUT1	Control output 1
OUT2	Control output 2 (option)
AT	Auto-tuning
DC input	DC voltage and current inputs

Characters Used in This Manual:

Indication	-1	0	1	2	3	4	5	6	7	8	9	℃	℉	
Number, °C/°F	-1	0	1	2	3	4	5	6	7	8	9	°C	°F	
Indication	A	B	C	D	E	F	G	H	I	J	K	L	M	
Alphabet	A	B	C	D	E	F	G	H	I	J	K	L	M	
Indication	N	O	P	Q	R	S	T	U	V	W	X	Y	Z	
Alphabet	N	O	P	Q	R	S	T	U	V	W	X	Y	Z	

Notes

- This instrument should be used in accordance with the specifications described in the manual. If it is not used according to the specifications, it may malfunction or cause a fire.
- Be sure to follow the warnings, cautions and notices. If they are not observed, serious injury or malfunction may occur.
- Specifications of the JCM-33A and the contents of this instruction manual are subject to change without notice.
- Care has been taken to ensure that the contents of this instruction manual are correct, but if there are any doubts, mistakes or questions, please inform our sales department.
- Measures must be taken to ensure that the operator does not touch power terminals or other high voltage sections.
- Any unauthorized transfer or copying of this document, in part or in whole, is prohibited.
- Shinko Technos CO., LTD. is not liable for any damage or secondary damage(s) incurred as a result of using this product, including any indirect damage.

SAFETY PRECAUTIONS (Be sure to read these precautions before using our products.)

The safety precautions are classified into categories: "Warning" and "Caution".

Depending on the circumstances, procedures indicated by  Caution may cause serious results, so be sure to follow the directions for usage.



Warning

Procedures which may lead to dangerous conditions and cause death or serious injury, if not carried out properly.



Caution

Procedures which may lead to dangerous conditions and cause superficial to medium injury or physical damage or may degrade or damage the product, if not carried out properly.



Warning

- To prevent an electric shock or fire, only Shinko or other qualified service personnel may handle the inner assembly.
- To prevent an electric shock, fire or damage to the instrument, parts replacement may only be undertaken by Shinko technicians or other qualified personnel.



SAFETY PRECAUTIONS

- To ensure safe and correct use, thoroughly read and understand this manual before using this instrument.
- This instrument is intended to be used for industrial machinery, machine tools and measuring equipment. Verify correct usage after purpose-of-use consultation with our agency or main office.
(Never use this instrument for medical purposes with which human lives are involved.)
- External protection devices such as protective equipment against excessive temperature rise, etc. must be installed, as malfunction of this product could result in serious damage to the system or injury to personnel. Also proper periodic maintenance is required.
- This instrument must be used under the conditions and environment described in this manual.

Shinko Technos Co., Ltd. does not accept liability for any injury, loss of life or damage occurring due to the instrument being used under conditions not otherwise stated in this manual.



Caution with respect to Export Trade Control Ordinance

To avoid this instrument from being used as a component in, or as being utilized in the manufacture of weapons of mass destruction (i.e. military applications, military equipment, etc.), please investigate the end users and the final use of this instrument.
In the case of resale, ensure that this instrument is not illegally exported.

1. Installation Precautions



Caution

This instrument is intended to be used under the following environmental conditions (IEC61010-1): Overvoltage category II, Pollution degree 2

Ensure the mounting location corresponds to the following conditions:

- A minimum of dust, and an absence of corrosive gases
- No flammable, explosive gases
- No mechanical vibrations or shocks
- No exposure to direct sunlight, an ambient temperature of 0 to 50°C (32 to 122°F) that does not change rapidly, and no icing
- An ambient non-condensing humidity of 35 to 85%RH
- No large capacity electromagnetic switches or cables through which large current is flowing
- No water, oil or chemicals or where the vapors of these substances can come into direct contact with the unit
- Take note that ambient temperature of this unit must not exceed 50°C (122°F) if mounted through the face of a control panel. Otherwise the life of electronic components (especially electrolytic capacitors) may be shortened.

Note: Do not install this instrument on or near flammable material even though the case of this instrument is made of flame-resistant resin.

2. Wiring Precautions



Caution

- Do not leave wire remnants in the instrument, because they could cause a fire and/or a malfunction.
- Use the solderless terminal with an insulation sleeve in which the M3 screw fits when wiring the JCM-33A Series.
- The terminal block of this instrument is designed to be wired from the left side. The lead wire must be inserted from the left side of the terminal, and fastened with the terminal screw.
- Tighten the terminal screw using the specified torque. If excessive force is applied to the screw when tightening, the terminal screw or case may be damaged.
- Do not apply a commercial power source to the sensor which is connected to the input terminal nor allow the power source to come into contact with the sensor.
- This controller does not have a built-in power switch, circuit breaker or fuse. It is necessary to install them near the controller.
(Recommended fuse: Time-lag fuse, rated voltage 250V AC, rated current 2A)
- 24V AC or DC is usable as a power source, however, do not confuse polarity when using direct current (DC).

3. Operation and Maintenance Precautions



Warning

- It is recommended that auto-tuning be performed during the trial run.
- Do not touch live terminals. This may cause electric shock or problems in operation.
- Turn the power supply to the instrument OFF before retightening the terminal and cleaning. Working or touching the terminal with the power switched ON may result in severe injury or death due to Electric Shock.
- Use a soft, dry cloth when cleaning the instrument.
(Alcohol based substances may tarnish or deface the unit.)
- As the display section is vulnerable, do not strike or scratch it with a hard object.

--- CONTENTS ---

1. Model	6
1.1 Model	6
1.2 Rated Input	7
1.3 How to Read the Model Label	7
2. Name and Functions of Sections	8
3. Mounting to the Control Panel	10
3.1 Site Selection	10
3.2 External Dimensions (Scale: mm)	10
3.3 Panel Cutout (Scale: mm)	10
3.4 CT (Current transformer) External Dimensions (Scale: mm)	11
3.5 Mounting	11
4. Wiring	12
4.1 Terminal Arrangement	12
4.2 Wiring Examples	13
5. Setup	15
5.1 Operation Flowchart	16
5.2 Main Setting Mode	18
5.3 Sub Setting Mode	18
5.4 Auxiliary Function Setting Mode 1	21
5.5 Auxiliary Function Setting Mode 2	22
5.6 Control Output OFF Function	27
5.7 Auto/Manual Control Switching	27
5.8 MV Indication	27
6. Operation	28
7. Action Explanation	29
7.1 OUT1 Action	29
7.2 Heater Burnout Alarm Action (Option)	29
7.3 OUT1 ON/OFF Control Action	30
7.4 OUT2 (Heating/Cooling Control) Action (Option)	31
7.5 A1 and A2 Actions	34
8. Control Action Explanations	36
8.1 PID	36
8.2 AT of This Controller	36
8.3 Auto-reset (Offset Correction)	37
9. Specifications	38
9.1 Standard Specifications	38
9.2 Optional Specifications	42
9.3 Option Combinations	44
10. Troubleshooting	44
11. Character Table	46

1. Model

1.1 Model

The series name, control output (OUT1), input and option codes are entered where underlined.

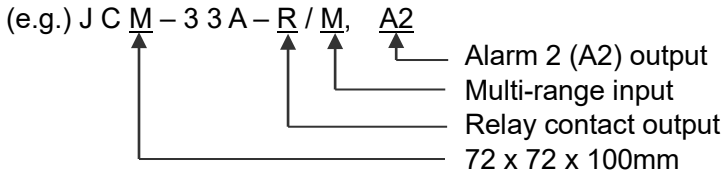

Specifications

J C M - 3 3 A - <input type="checkbox"/> / <input type="checkbox"/> <input type="checkbox"/> , <input type="checkbox"/>			
Alarm 1 (A1)	A	Alarm type can be selected by keypad. *1	
Control output (OUT1)	R	Relay contact	
	S	Non-contact voltage (for SSR drive)	
	A	Current	
Input	M	Multi-range *2	
Supply voltage		100 to 240 V AC (standard)	
	1	24 V AC/DC *3	
Options	A2	Alarm 2 (A2) *4	
	W	Heater burnout alarm *5	
	D <input type="checkbox"/>	Heating/Cooling control, Control output (OUT2)	DR: Relay contact output
			DS: Non-contact voltage output
			DA: Current output
	C5	Serial communication (RS-485)	
	LA	Loop break alarm *4	
	P24	Insulated power output	
	BK	Color: Black	
TC	Terminal cover		
IP	Drip-proof/Dust-proof (IP54)		

*1: 9 types of alarm plus No alarm action and Energized/De-energized are selectable by keypad.

*2: An input type (10 thermocouple, 2 RTD, 2 direct current and 4 DC voltage types) can be selected by keypad.

For current input, 50 Ω shunt resistor must be connected between input terminals.

*3: For the supply voltage, 100 to 240 V AC is standard.

When ordering 24 V AC/DC, enter "1" after the input code.

*4: If A2 option and LA option are added together, they utilize common output terminals.

*5: For current output, Heater burnout alarm option cannot be added.

Option Combinations

	A2	LA	W	D <input type="checkbox"/>	P24	C5	BK	TC	IP
Combination 1	O	O	O	-	-	O	O	O	O
Combination 2	O	O	-	O	-	O	O	O	O
Combination 3	-	-	O	O	-	O	O	O	O
Combination 4	O	O	-	-	O	O	O	O	O
Combination 5	O	O	O	-	-	-	O	O	O
Combination 6	O	O	-	O	-	-	O	O	O
Combination 7	-	-	O	O	-	-	O	O	O
Combination 8	O	O	-	-	O	-	O	O	O

D: DR, DS, DA

O: Available

-: Unavailable

1.2 Rated Input

Input type	Input range		Resolution
K	-200 to 1370 °C	-320 to 2500 °F	1°C(°F)
	-199.9 to 400.0 °C	-199.9 to 750.0 °F	0.1°C(°F)
J	-200 to 1000 °C	-320 to 1800 °F	1°C(°F)
R	0 to 1760 °C	0 to 3200 °F	1°C(°F)
S	0 to 1760 °C	0 to 3200 °F	1°C(°F)
B	0 to 1820 °C	0 to 3300 °F	1°C(°F)
E	-200 to 800 °C	-320 to 1500 °F	1°C(°F)
T	-199.9 to 400.0 °C	-199.9 to 750.0 °F	0.1°C(°F)
N	-200 to 1300 °C	-320 to 2300 °F	1°C(°F)
PL-II	0 to 1390 °C	0 to 2500 °F	1°C(°F)
C (W/Re5-26)	0 to 2315 °C	0 to 4200 °F	1°C(°F)
Pt100	-199.9 to 850.0 °C	-199.9 to 999.9 °F	0.1°C(°F)
	-200 to 850 °C	-300 to 1500 °F	1°C(°F)
JPt100	-199.9 to 500.0 °C	-199.9 to 900.0 °F	0.1°C(°F)
	-200 to 500 °C	-300 to 900 °F	1°C(°F)
4 to 20 mA DC	-1999 to 9999 *1, *2		1
0 to 20 mA DC	-1999 to 9999 *1, *2		1
0 to 1 V DC	-1999 to 9999 *1		1
0 to 5 V DC	-1999 to 9999 *1		1
1 to 5 V DC	-1999 to 9999 *1		1
0 to 10 V DC	-1999 to 9999 *1		1

*1: For DC input, input range and decimal point place can be changed.

*2: For current input, connect 50 Ω shunt resistor (sold separately) between input terminals.

1.3 How to Read the Model Label

Model labels are attached to the case and the inner assembly.

When the supply voltage is 24V AC/DC, "1" is entered before the option code.

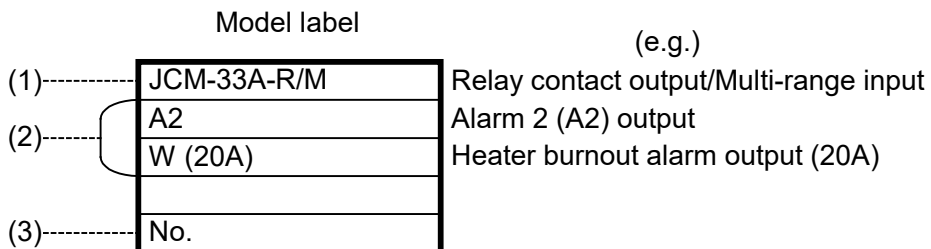

(1): Model

(2): Options

(3): Serial number

(Fig. 1.3-1)

2. Name and Functions of Sections

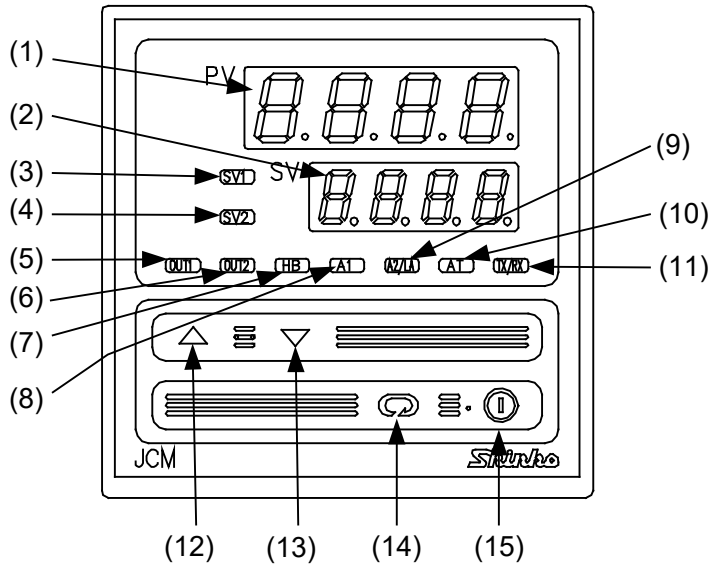

(Fig. 2-1)

(1) PV display

Indicates the PV or setting characters in the setting mode with a red LED.

(2) SV display

Indicates the SV, MV or each set value in the setting mode with a green LED.

(3) SV1 indicator

The green LED is lit when SV1 is selected.

(4) SV2 indicator

Does not function.

(5) OUT1 indicator

When OUT1 is ON, the green LED is lit.

(For the current output type, this flashes corresponding to the MV in 250 ms cycles.)

(6) OUT2 indicator

When OUT2 (D□ option) is ON, the yellow LED is lit.

(For the current output type, this flashes corresponding to the MV in 250 ms cycles.)

(7) HB indicator

When Heater burnout alarm output or sensor burnout alarm output is ON, the red LED is lit.

(When Heater burnout alarm is added and if indication is overscale or underscale, the red LED is lit as well.)

(8) A1 indicator

When A1 output is ON, the red LED is lit.

(9) A2/LA indicator

When A2 or LA output is ON, the red LED is lit.

(10) AT indicator

The yellow LED flashes during AT or auto-reset.

(11) TX/RX indicator

The yellow LED is lit during Serial communication TX output (transmission).

(12) Increase Key (△)

Increases the numeric value.

(13) Decrease Key (▽)

Decreases the numeric value.

(14) Mode Key (⊞)

Selects the setting mode or registers the set value.

[By pressing the Mode Key, the set (or selected) value can be registered.]

(15) OUT/OFF Key (⓪)

Switches Control output OFF or Auto/Manual control.

To release the Control output OFF function, press this key for approx. 1 second.

- If Control output OFF function is selected during OUT/OFF Key function selection mode, the control output can be turned on or off.

Once the Control output OFF function is enabled, the function cannot be released even if the power to the instrument is turned OFF and turned ON again.

To cancel the function, press the OUT/OFF Key again for approx. 1 second.

- If Auto/Manual control function is selected during OUT/OFF Key function selection, automatic control is performed when the power to the controller is turned on. In this status, if the OUT/OFF Key is pressed, the automatic control output is switched to manual control output and vice versa.

This function can be switched only in the PV/SV display mode.



Notice

When setting the specifications and functions of this controller, connect terminals 2 and 4 for power source first, then set them referring to “5. Setup” before performing “3. Mounting to the Control Panel” and “4. Wiring”.

(Be sure to perform input specification change at this time.)

3. Mounting to the Control Panel

3.1 Site Selection

This instrument is intended to be used under the following environmental conditions (IEC61010-1): **Overvoltage category II, Pollution degree 2**

Ensure the mounting location corresponds to the following conditions:

- (1) A minimum of dust, and an absence of corrosive gases
- (2) No flammable, explosive gases
- (3) No mechanical vibrations or shocks
- (4) No exposure to direct sunlight, an ambient temperature of 0 to 50°C (32 to 122°F) that does not change rapidly, and no icing
- (5) An ambient non-condensing humidity of 35 to 85%RH
- (6) No large capacity electromagnetic switches or cables through which large current is flowing
- (7) No water, oil or chemicals or where the vapors of these substances can come into direct contact with the unit
- (8) Take note that ambient temperature of this unit must not exceed 50°C (122°F) if mounted through the face of a control panel. Otherwise the life of electronic components (especially electrolytic capacitors) may be shortened.

3.2 External Dimensions (Scale: mm)

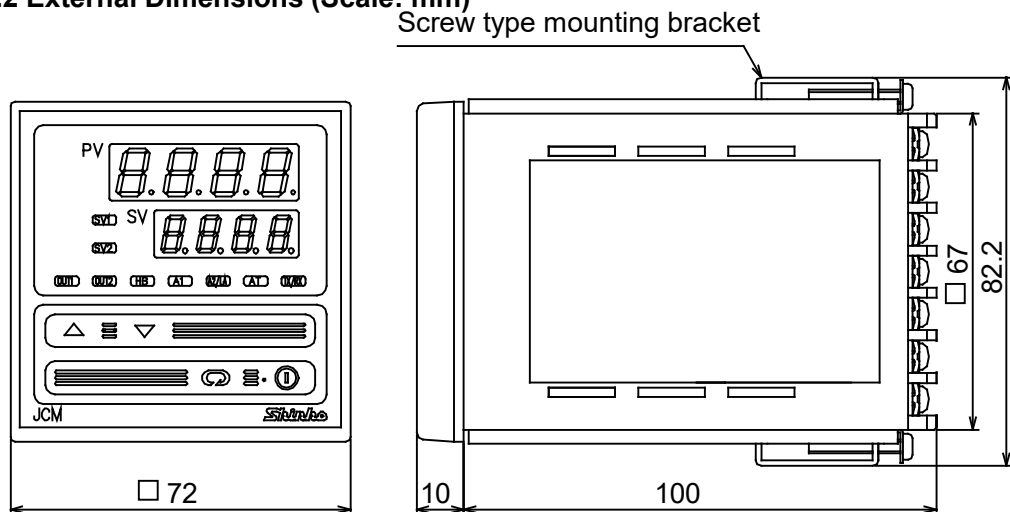

(Fig. 3.2-1)

3.3 Panel Cutout (Scale: mm)

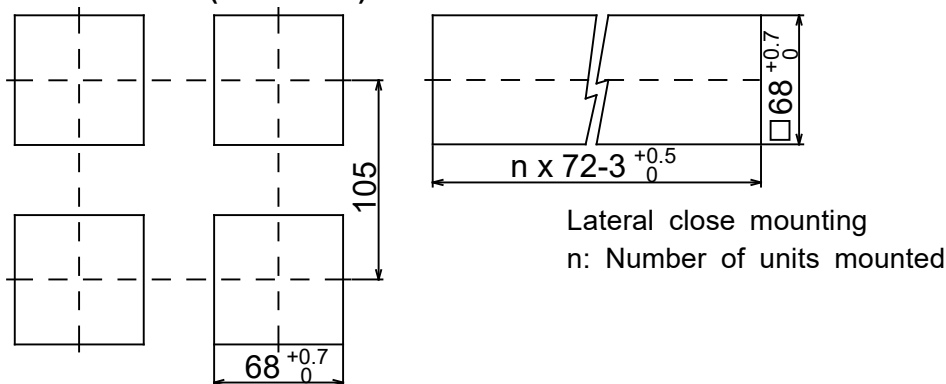

(Fig. 3.3-1)

3.4 CT (Current transformer) External Dimensions (Scale: mm)

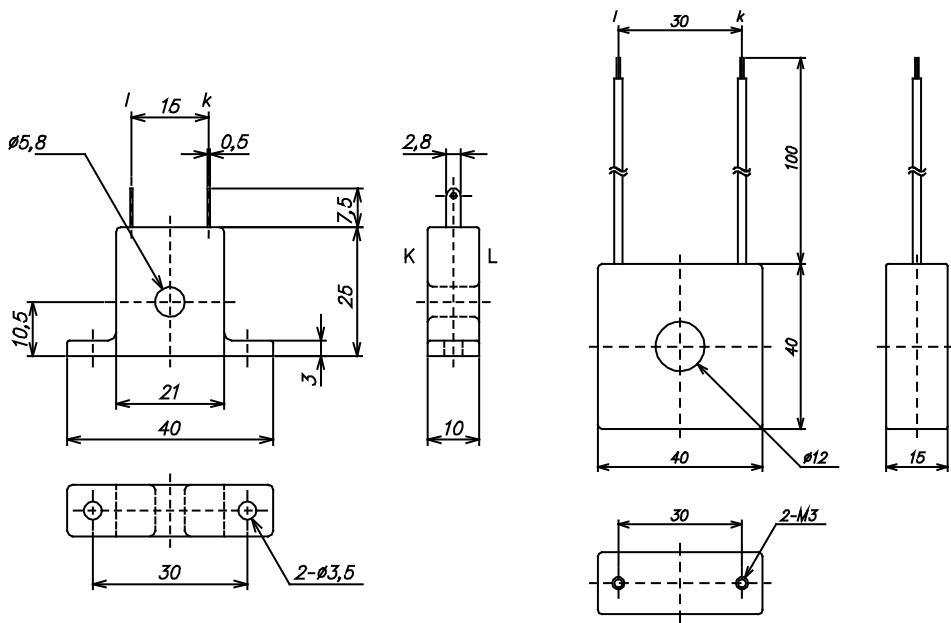

CTL-6S (for 5A, 10A, 20A)

CTL-12-S36-10L1U (for 50A)

(Fig. 3.4-1)

3.5 Mounting



Notice

As the case is made of resin, do not use excessive force while screwing in the mounting bracket, or the case or screw type mounting bracket could be damaged. The torque should be 0.12 N•m.

Mounting panel thickness is 1 to 8 mm.

Insert the instrument from the front side of the panel.

Attach the mounting bracket by the holes at the top and bottom of the case, and secure in place with the screws.

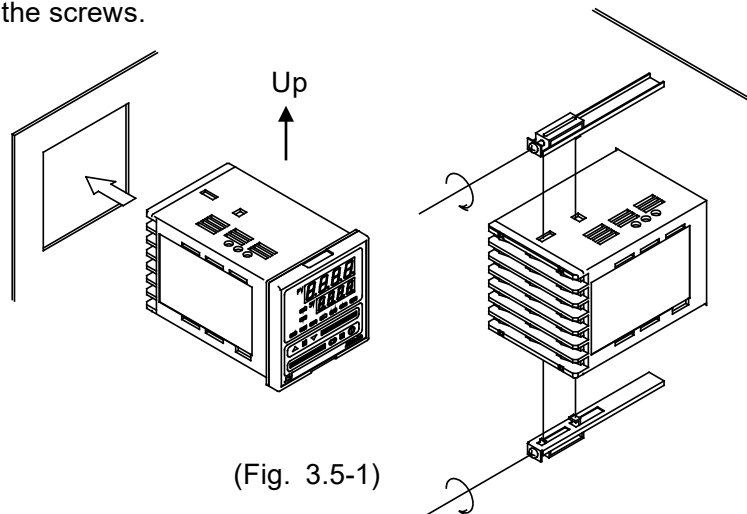

(Fig. 3.5-1)

4. Wiring



Warning

Turn the power supply to the instrument off before wiring or checking.
 Working on or touching the terminal with the power switched on may result in severe injury or death due to Electric Shock.
 Moreover, the instrument must be grounded before the power supply to the instrument is turned on.

4.1 Terminal Arrangement

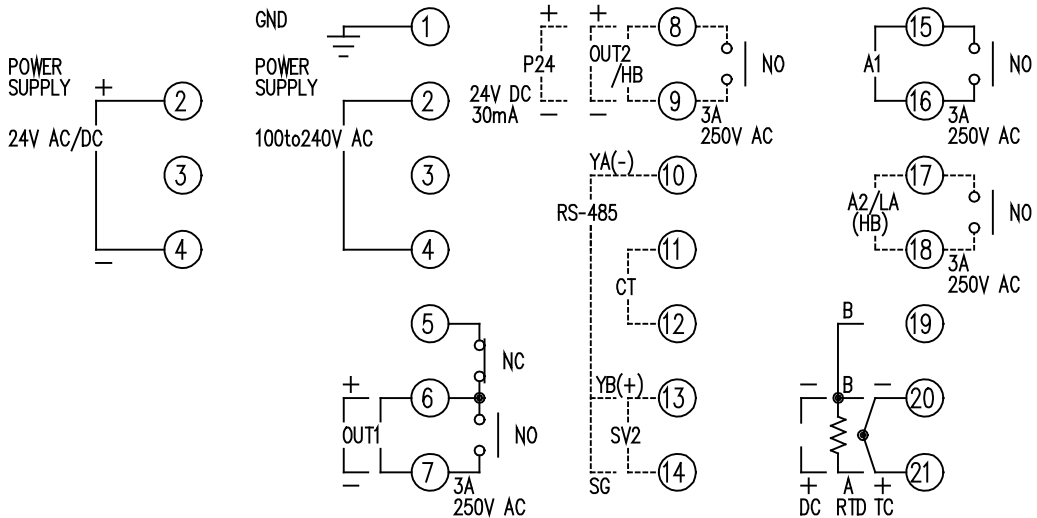

(Fig. 4.1-1)

- GND: Grounding
- OUT1: Control output 1
- OUT2/HB: Control output 2 (D□ option) or Heater burnout alarm output
- P24: Insulated power output 24 V DC
- RS-485: Serial communication (RS-485)
- CT: CT input
- SV2: Does not function
- A1: Alarm 1 output
- A2/LA(HB): Alarm 2, Loop break alarm or Heater burnout alarm output
- TC: Thermocouple input
- RTD: RTD input
- DC: Direct current input, DC voltage input

For current input, 50 Ω shunt resistor must be connected between input terminals.



Notice

- The terminal block of JCM-33A series is designed to be wired from the left side. The lead wire must be inserted from the left side of the terminal, and fastened with the terminal screw.
- Terminals with dotted lines show options, and they are equipped only when the options are added.
- If A2 (option) and Heater burnout alarm (option) are added together, use terminals 17 and 18 for the A2, and 8 and 9 for the Heater burnout alarm.
- If the Heating/Cooling control (option) and Heater burnout alarm (option) are added together, use terminals 8 and 9 for the Heating/Cooling control, and 17 and 18 for the Heater burnout alarm.
- When only Heater burnout alarm (option) is added, use terminals 8 and 9.
- When A2 (option) and LA (option) are added together, they utilize common output terminals.
- If the Insulated power output (option) is added, Heating/Cooling control (option) and Heater burnout alarm (option) cannot be added.

● Lead Wire Solderless Terminal

Use a solderless terminal with an insulation sleeve in which an M3 screw fits as shown below. The tightening torque should be 0.63 N•m.

Solderless terminal	Manufacturer	Model	Tightening torque
Y type	Nichifu Terminal Industries CO.,LTD.	TMEX1.25Y-3	0.63 N•m
	Japan Solderless Terminal MFG CO.,LTD.	VD1.25-B3A	
Ring type	Nichifu Terminal Industries CO.,LTD.	TMEX1.25-3	
	Japan Solderless Terminal MFG CO.,LTD.	V1.25-3	



(Fig. 4.1-2)

4.2 Wiring Examples



Notice

- Use a thermocouple and compensating lead wire according to the sensor input specifications of this controller.
- Use the 3-wire RTD according to the sensor input specifications of this controller.
- This controller does not have a built-in power switch, circuit breaker or fuse. It is necessary to install them in the circuit near the external controller.
(Recommended fuse: Time-lag fuse, rated voltage 250 V AC, rated current 2 A)
- For a 24 V AC/DC power source, do not confuse polarity when using direct current (DC).
- When using a relay contact output type, use a relay externally according to the capacity of the load to protect the built-in relay contact.
To prevent the unit from harmful effects of unexpected high level noise, it is recommended that a surge absorber be installed between the electromagnetic switch coils.
- When wiring, keep the input wire (Thermocouple, RTD, etc.) away from AC sources or load wires.
- Use a thick wire (1.25 to 2.0 mm²) for grounding.

[Heater Burnout Alarm Output]

- (1) **This alarm is not available for detecting heater current under phase control.**
- (2) Use the current transformer (CT) provided, and pass one lead wire of the heater circuit into the hole of the CT. Solder the lead wires from the CT input terminals to the CT terminals. (There is no polarity.)
- (3) When wiring, keep CT wire away from any AC source and load wire to avoid external interference.

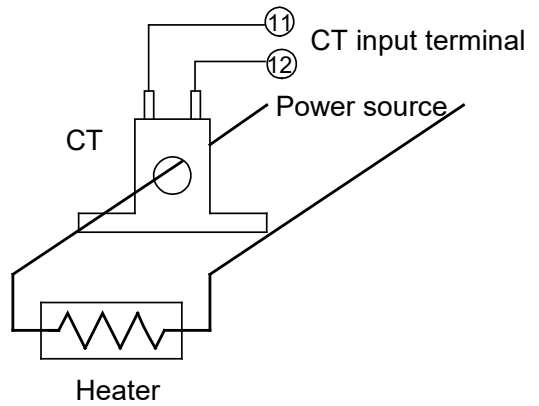

(Fig. 4.2-1)

[JCM-33A-S/E]

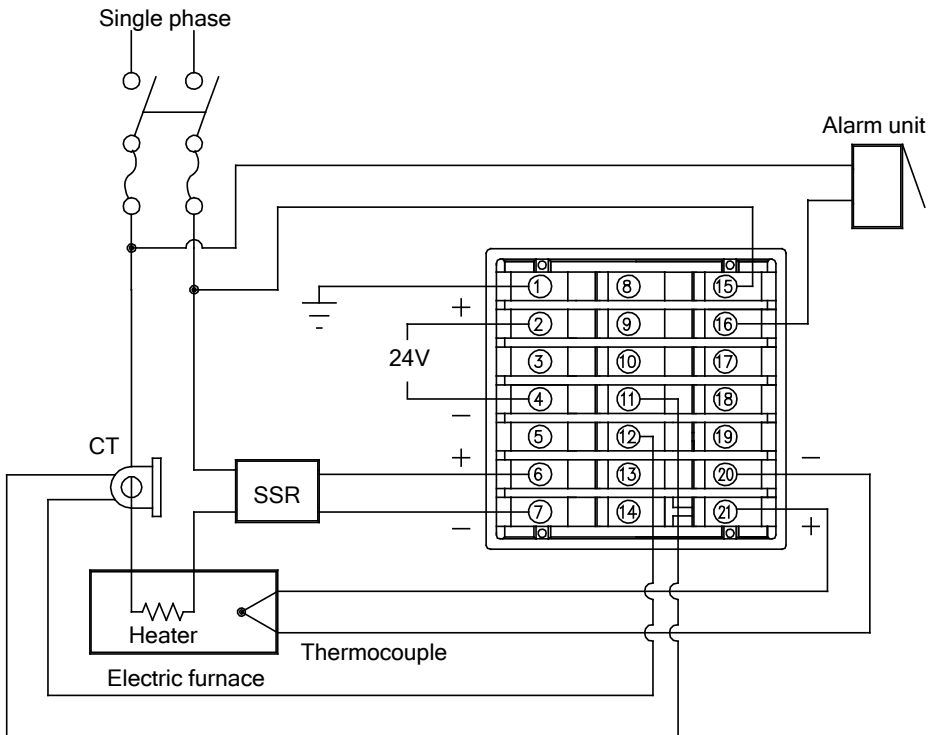

(Fig. 4.2-2)

- For a 24 V AC/DC power source, do not confuse polarity when using direct current (DC).
- When using Shinko SSR, the number of parallel connections is as follows.
 SA-400 series: 5 units
 SA-500 series: 2 units

5. Setup

For the thermocouple and RTD input, the sensor input characters and temperature unit are indicated on the PV display, and the input range high limit value is indicated on the SV display for approx. 3 seconds after the power is turned on. See (Table 5-1).

For DC input, the sensor input characters are indicated on the PV display, and the scaling high limit value is indicated on the SV display. See (Table 5-1).

If any other value is set during the scaling high limit setting, the value will be indicated on the SV display.

During this time, all outputs and the LED indicators are in OFF status.

Control will start indicating the PV on the PV display and SV1 on the SV display.

While Control output OFF function is working, $\square FF \square$ is indicated on the PV display.

To cancel this function, press the OUT/OFF Key for approx. 1 second.

(Table 5-1)

Sensor input	°C		°F	
	PV display	SV display	PV display	SV display
K	$\square \square \square C$	1370	$\square \square \square F$	2500
	$\square \square \square C$	4000	$\square \square \square F$	7500
J	$\square \square \square C$	1000	$\square \square \square F$	1800
R	$\square \square \square C$	1760	$\square \square \square F$	3200
S	$\square \square \square C$	1760	$\square \square \square F$	3200
B	$\square \square \square C$	1820	$\square \square \square F$	3300
E	$\square \square \square C$	$\square 800$	$\square \square \square F$	1500
T	$\square \square \square C$	4000	$\square \square \square F$	7500
N	$\square \square \square C$	1300	$\square \square \square F$	2300
PL-II	$\square \square \square C$	1390	$\square \square \square F$	2500
C (W/Re5-26)	$\square \square \square C$	2375	$\square \square \square F$	4200
Pt100	$\square \square \square C$	8500	$\square \square \square F$	9999
	$\square \square \square C$	$\square 850$	$\square \square \square F$	1500
JPt100	$\square \square \square C$	5000	$\square \square \square F$	9000
	$\square \square \square C$	$\square 500$	$\square \square \square F$	$\square 900$
4 to 20 mA DC	$\square \square \square C$	Scaling high limit value		
0 to 20 mA DC	$\square \square \square C$			
0 to 1 V DC	$\square \square \square C$			
0 to 5 V DC	$\square \square \square C$			
1 to 5 V DC	$\square \square \square C$			
0 to 10 V DC	$\square \square \square C$			

5.1 Operation Flowchart

Outline of Operation Procedure

Set Input type, Alarm (type, value, etc.) and SV, following the procedures below. Setting item numbers (1) to (7) are indicated on the flowchart.

[Step 1 Operation before Run]	Turn the load circuit power OFF, and turn the power supply to the JCM-33A ON.
[Step 2 Auxiliary function setting mode 2]	Set Input type and Alarm type, etc. in Auxiliary function setting mode 2. (1) Input type: Select an input type. Refer to "Input type (character indication) and range" on page 17. (2) A1 type: Select Alarm 1 type. Refer to "Alarm type" on page 17. [If an alarm type except for "----" is selected, items (3) to (5) will be indicated and they can be set if necessary.] Note: If an alarm type is changed, the alarm set value becomes 0 (0.0). Therefore it is necessary to set it again. (3) A1 action Energized/De-energized: Select Alarm 1 action Energized or De-energized. (4) A1 hysteresis: Set A1 hysteresis. (5) A1 action delay timer: Set A1 action delay time.
[Step 3 Sub setting mode]	(6) A1 value: Set action point of A1 output in the Sub setting mode.
[Step 4 Main setting mode]	(7) SV1: Set SV in the Main setting mode.
[Step 5 Run]	Turn the load circuit power ON. Control action starts so as to keep the control target at the SV.

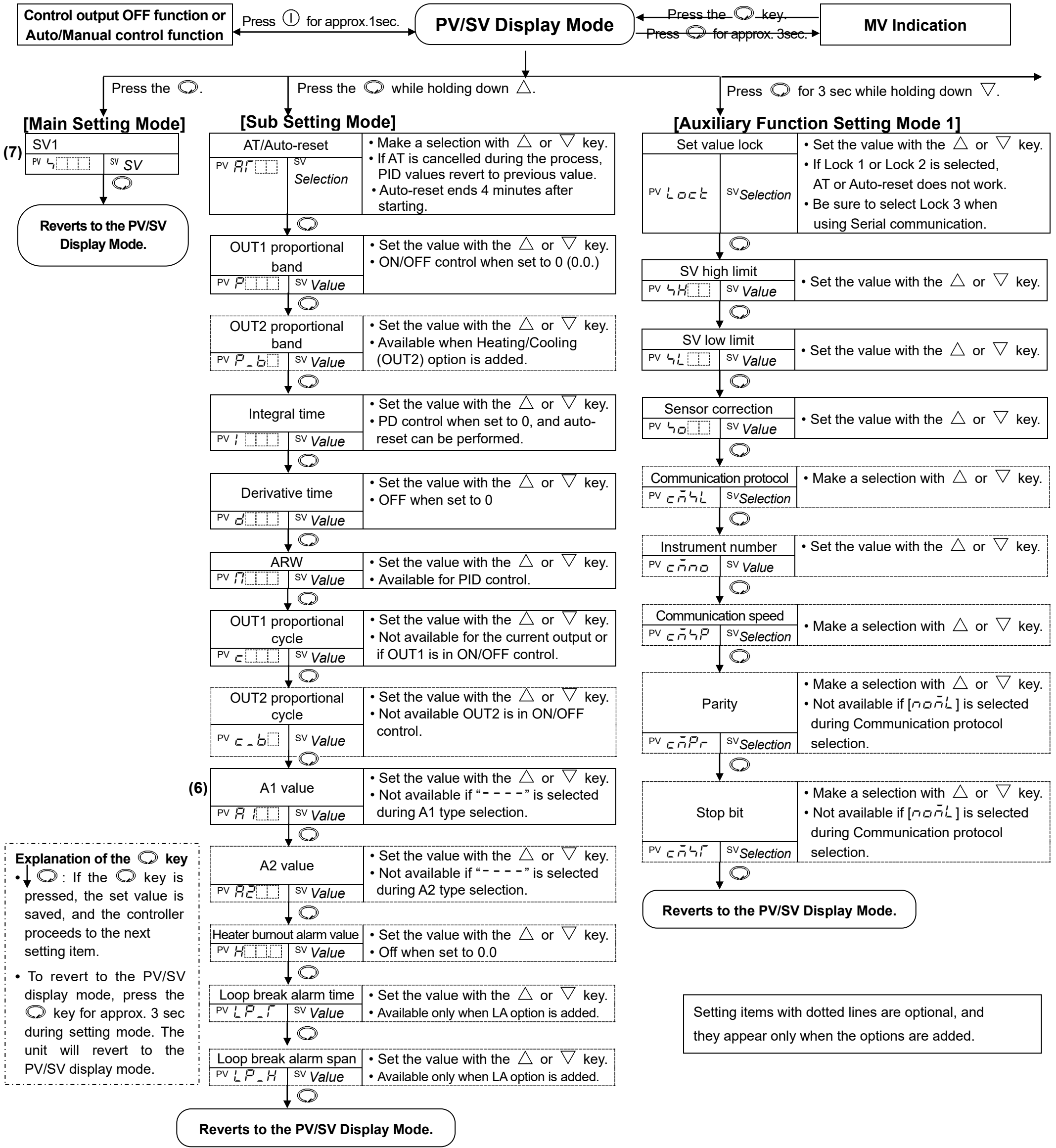

Input Type (character indication) and Range			
$\bar{E} \square \square \square$: K	-200 to 1370 °C	$\bar{E} \square \square \square$: K	-320 to 2500 °F
$\bar{E} \square \square \square$	-199.9 to 400.0 °C	$\bar{E} \square \square \square$	-199.9 to 750.0 °F
$\bar{J} \square \square \square$: J	-200 to 1000 °C	$\bar{J} \square \square \square$: J	-320 to 1800 °F
$\bar{r} \square \square \square$: R	0 to 1760 °C	$\bar{r} \square \square \square$: R	0 to 3200 °F
$\bar{4} \square \square \square$: S	0 to 1760 °C	$\bar{4} \square \square \square$: S	0 to 3200 °F
$\bar{b} \square \square \square$: B	0 to 1820 °C	$\bar{b} \square \square \square$: B	0 to 3300 °F
$\bar{E} \square \square \square$: E	-200 to 800 °C	$\bar{E} \square \square \square$: E	-320 to 1500 °F
$\bar{r} \square \square \square$: T	-199.9 to 400.0 °C	$\bar{r} \square \square \square$: T	-199.9 to 750.0 °F
$\bar{n} \square \square \square$: N	-200 to 1300 °C	$\bar{n} \square \square \square$: N	-320 to 2300 °F
$\bar{P} \bar{L} \bar{Z} \bar{C}$: PL-II	0 to 1390 °C	$\bar{P} \bar{L} \bar{Z} \bar{F}$: PL-II	0 to 2500 °F
$\bar{C} \square \square \square$: C(W/Re5-26)	0 to 2315 °C	$\bar{C} \square \square \square$: C(W/Re5-26)	0 to 4200 °F
$\bar{P} \bar{T} \bar{C}$: Pt100	-199.9 to 850.0 °C	$\bar{P} \bar{T} \bar{F}$: Pt100	-199.9 to 999.9 °F
$\bar{J} \bar{P} \bar{T} \bar{C}$: JPt100	-199.9 to 500.0 °C	$\bar{J} \bar{P} \bar{T} \bar{F}$: JPt100	-199.9 to 900.0 °F
$\bar{P} \bar{T} \bar{C}$: Pt100	-200 to 850 °C	$\bar{P} \bar{T} \bar{F}$: Pt100	-300 to 1500 °F
$\bar{J} \bar{P} \bar{T} \bar{C}$: JPt100	-200 to 500 °C	$\bar{J} \bar{P} \bar{T} \bar{F}$: JPt100	-300 to 900 °F
$\bar{4} \bar{2} \bar{0} \bar{A}$: 4 to 20 mA DC	-1999 to 9999		
$\bar{0} \bar{2} \bar{0} \bar{A}$: 0 to 20 mA DC	-1999 to 9999		
$\bar{0} \bar{1} \bar{V}$: 0 to 1 V DC	-1999 to 9999		
$\bar{0} \bar{5} \bar{V}$: 0 to 5 V DC	-1999 to 9999		
$\bar{1} \bar{0} \bar{V}$: 1 to 5 V DC	-1999 to 9999		
$\bar{0} \bar{1} \bar{0} \bar{V}$: 0 to 10 V DC	-1999 to 9999		

Alarm type	
$\bar{H} \square \square \square$ (High limit alarm):	The alarm action is \pm deviation setting from the SV. The alarm is activated if the input value reaches the high limit set value.
$\bar{L} \square \square \square$ (Low limit alarm):	The alarm action is \pm deviation setting from the SV. The alarm is activated if the input value goes under the low limit set value.
$\bar{H} \bar{L} \square \square$ (High/Low limits alarm):	Combines High limit and Low limit alarm actions. When input value reaches high limit set value or goes under the low limit set value, the alarm is activated.
$\bar{u} \bar{l} \bar{d}$ (High/Low limit range alarm):	When input value is between the high limit set value and low limit set value, the alarm is activated.
$\bar{R} \bar{4} \square \square$ (Process high alarm), $\bar{r} \bar{R} \bar{4} \square \square$ (Process low alarm):	Within the input range of the controller, alarm action points can be set at random and if the input reaches the randomly set action point, the alarm is activated.
$\bar{H} \square \square \bar{u}$ (High limit alarm with standby), $\bar{L} \square \square \bar{u}$ (Low limit alarm with standby), $\bar{H} \bar{L} \square \bar{u}$ (High/Low limits alarm with standby):	After the power supply to the instrument is turned on, even if the input enters the alarm action range, the alarm is not activated. If SV is changed while the controller is running, the alarm is not activated even if input is in the alarm action range. (If the controller is allowed to keep running, once the input exceeds the alarm action point, the standby function will be released.)

Press ∇ key for approx. 3 sec while holding down the \triangle key.

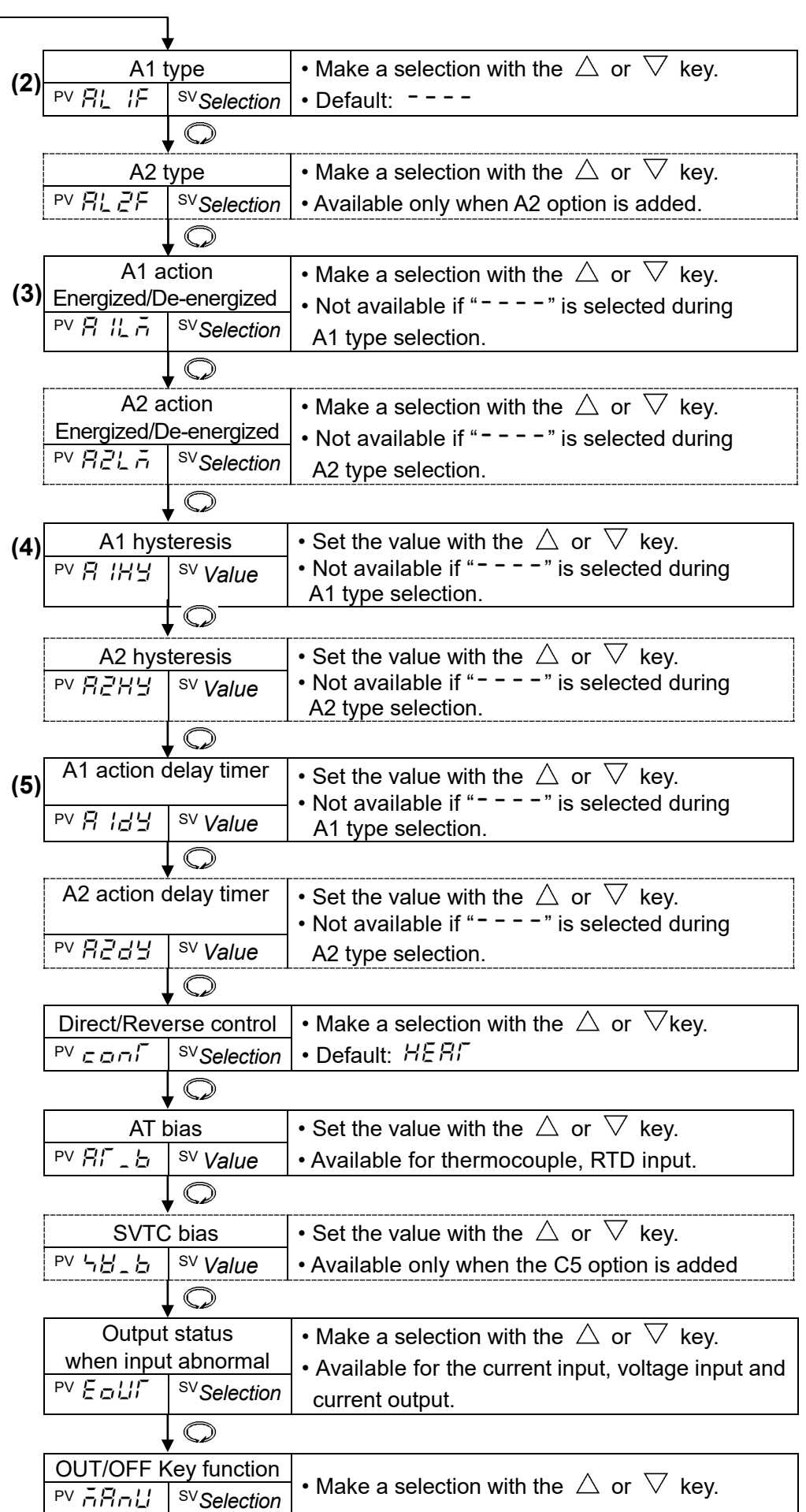
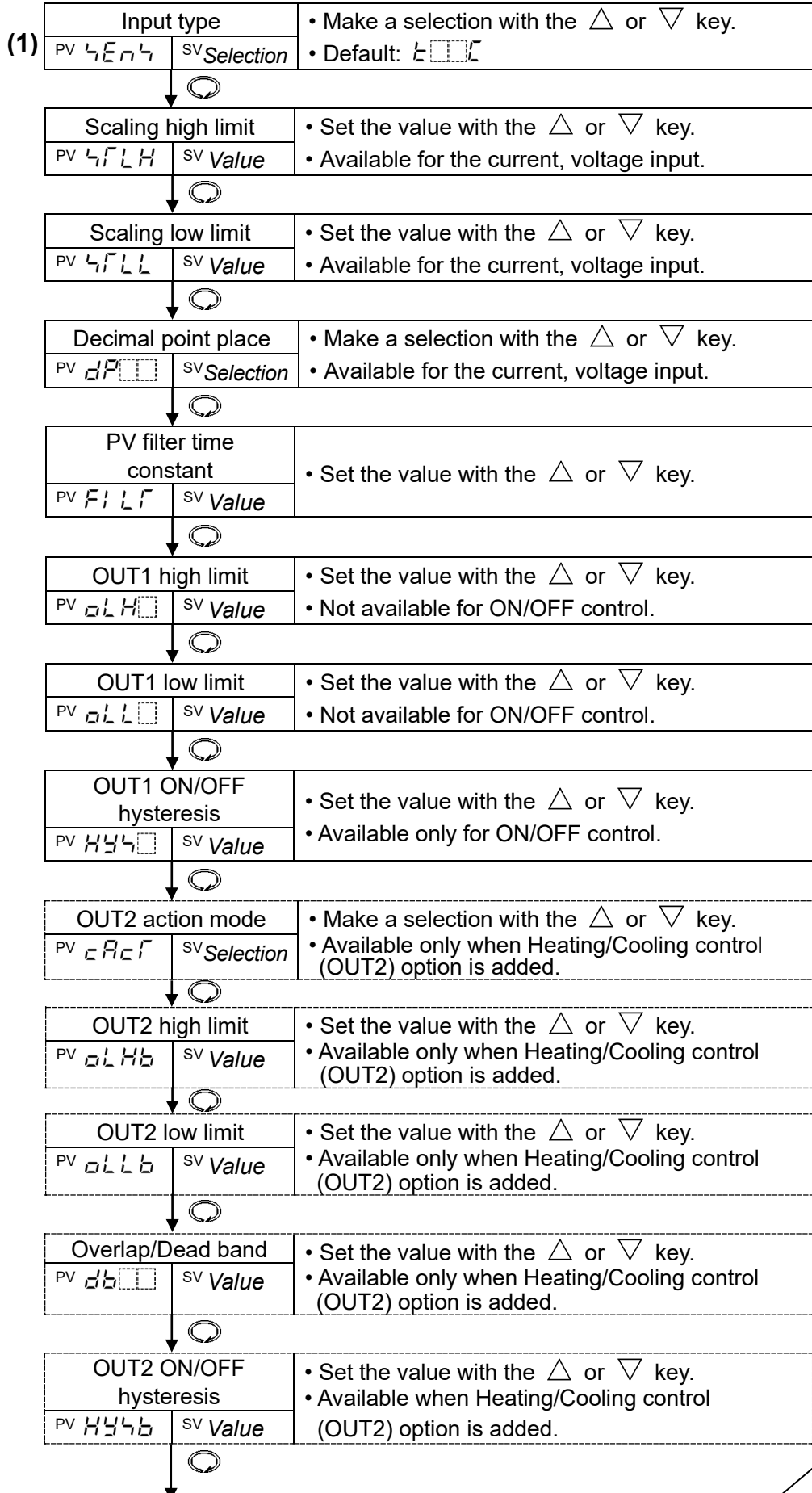

[Auxiliary Function Setting Mode 2]





Reverts to the PV/SV Display Mode.

5.2 Main Setting Mode

To enter the Main setting mode, press the  key.



The SV can be increased or decreased with the  or  key.

Pressing the  key registers the SV, and proceeds to the PV/SV Display mode.





Character	Name, Function, Setting range	Default value
	SV1 <ul style="list-style-type: none"> • Sets SV1 (desired value). • Setting range: SV low limit to SV high limit, or Scaling low limit to Scaling high limit value 	0°C

5.3 Sub Setting Mode

To enter the Sub setting mode, press the  key while holding down the  key.

The set values can be increased or decreased with the  or  key.

Pressing the  key registers the set value, and proceeds to the next setting item.

Character	Name, Function, Setting range	Default value
	AT/Auto-reset <ul style="list-style-type: none"> • Selects AT Perform/Cancel (PID control) or Auto-reset (offset correction) Perform/Cancel (PD or P control). Not available for ON/OFF or PI control. • Selection item: - - - - : AT/Auto-reset Cancel /r 4E7 : AT/Auto-reset Perform [AT (Auto-tuning)] <ul style="list-style-type: none"> • If AT Perform is selected, the AT indicator flashes, and the unit reverts to the PV/SV display mode. When AT is finished, the AT indicator is turned off and P, I, D, ARW values are automatically set. • During AT, none of the settings can be carried out. • If AT is cancelled during the process, P, I, D, ARW values return to the previous values. • If the  key (OUT/OFF Key) is pressed during AT, the Control output OFF function initiates. Pressing the  key again cancels the AT. • AT will be forced to stop if it has not been completed within 4 hours. [Auto-reset] <ul style="list-style-type: none"> • If Auto-reset Perform is selected, offset correction immediately starts, (correction value is automatically set, and the AT indicator flashes) and the unit reverts to the PV/SV display mode. • To prevent key entry error, other settings cannot be performed for 4 minutes after starting. After auto-reset is completed, the AT indicator is turned off, and all settings can be performed. 	AT/Auto-reset Cancel
	OUT1 Proportional Band <ul style="list-style-type: none"> • Sets OUT1 proportional band. • ON/OFF control when set to 0 or 0.0. • Setting range: 0 to 1000°C (0 to 2000°F) With a decimal point, 0.0 to 999.9°C (0.0 to 999.9°F) DC input: 0.0 to 100.0% 	10°C

Character	Name, Function, Setting range	Default value
P_b	OUT2 Proportional Band <ul style="list-style-type: none"> Sets OUT2 proportional band. OUT2 becomes ON/OFF control when set to 0.0. Not available if Heating/Cooling control (option) is not added, or if OUT1 is in ON/OFF control. Setting range: 0.0 to 10.0 times (Multiplied value of OUT1 proportional band) 	1.0 times
I	Integral Time <ul style="list-style-type: none"> Sets the integral time. Setting the value to 0 disables the function (PD control). Not available if OUT1 is in ON/OFF control Setting range: 0 to 1000 seconds 	200 sec
d	Derivative Time <ul style="list-style-type: none"> Sets the derivative time. Setting the value to 0 disables the function (PI control). Not available if OUT1 is in ON/OFF control Setting range: 0 to 300 seconds 	50 sec
n	ARW <ul style="list-style-type: none"> Sets the ARW (anti-reset windup). Available only for PID control. Setting range: 0 to 100% 	50%
c	OUT1 Proportional Cycle <ul style="list-style-type: none"> Sets OUT1 proportional cycle. Not available for the current output type or if OUT1 is in ON/OFF control. With the relay contact output type, if the proportional cycle time is decreased, the frequency of the relay action increases, and the life of the relay contact is shortened. Setting range: 1 to 120 seconds 	Relay contact output: 30 sec Non-contact voltage output: 3 sec
c_b	OUT2 Proportional Cycle <ul style="list-style-type: none"> Sets OUT2 proportional cycle. Not available for the current output type. Not available if Heating/Cooling control (option) is not added, or if OUT2 is in ON/OFF control. With the relay contact output type, if the proportional cycle time is decreased, the frequency of the relay action increases, and the life of the relay contact is shortened. Setting range: 1 to 120 seconds 	Relay contact output: 30 sec Non-contact voltage output: 3 sec
R 1	A1 Value <ul style="list-style-type: none"> Sets the action point of Alarm 1 (A1) output. Setting the value to 0 or 0.0 disables the function (except Process high and Process low alarm). Not available if No alarm action is selected during A1 type selection. Setting range: Refer to (Table 5.3-1) (p.20). 	0°C

Character	Name, Function, Setting range	Default value
A2	A2 Value <ul style="list-style-type: none"> Sets the action point of Alarm 2 (A2) output. Setting the value to 0 or 0.0 disables the function (except Process high and Process low alarm). Not available if A2 output (option) is not added or if No alarm action is selected during A2 type selection. Setting range: Refer to (Table 5.3-1). 	0°C
H, xx.x (xx.x: CT current value) Alternating display	Heater Burnout Alarm Value <ul style="list-style-type: none"> Sets the heater current value for Heater burnout alarm. Setting the value to 0.0 disables the function. Character <i>H</i> and CT current value are indicated alternately on the PV display. When OUT1 is ON, the CT current value is updated. When OUT1 is OFF, heater current value shows the same value as when OUT1 was ON. It is recommended to set approx. 80% of the heater current value in consideration of the voltage fluctuation. Upon returning to set limits, the alarm will stop. Available only when the Heater burnout alarm option is added. Setting range: Rated current 5 A: 0.0 to 5.0 A Rated current 10 A: 0.0 to 10.0 A Rated current 20 A: 0.0 to 20.0 A Rated current 50 A: 0.0 to 50.0 A 	0.0 A
LP_T	Loop Break Alarm Time <ul style="list-style-type: none"> Sets the time to assess the Loop break alarm. Available only when Loop break alarm (option) is added Setting range: 0 to 200 minutes 	0 min
LP_H	Loop Break Alarm Span <ul style="list-style-type: none"> Sets the span to assess the Loop break alarm. Available only when Loop break alarm (option) is added Setting range: 0 to 150°C With a decimal point: 0.0 to 150.0°C DC input: 0 to 1500 (The placement of the decimal point follows the selection.) 	0°C

Loop Break Alarm

The alarm will be activated when the PV does not **rise** as much as the span or more within the time it takes to assess the Loop break alarm after the manipulated variable has reached 100% or the output high limit value. The alarm will also be activated when the PV does not **fall** as much as the span or more within the time it takes to assess the Loop break alarm after the manipulated variable has reached 0% or the output low limit value. When the control action is Direct (Cooling), read “**fall**” for “**rise**” and vice versa.

Setting Range of A1 and A2 Value

(Table 5.3-1)



Alarm type	Setting range
High limit alarm	–Input span to input span °C (°F) (*1)
Low limit alarm	–Input span to input span °C (°F) (*1)
High/Low limits alarm	0 to input span °C (°F) (*1)
High/Low limit range alarm	0 to input span °C (°F) (*1)
Process high alarm	Input range low limit to input range high limit (*2)
Process low alarm	Input range low limit to input range high limit (*2)
High limit alarm with standby	–Input span to input span °C (°F) (*1)
Low limit alarm with standby	–Input span to input span °C (°F) (*1)
High/Low limits alarm with standby	0 to input span °C (°F) (*1)



When the input has a decimal point, the negative low limit value is –199.9, and the positive high limit value is 999.9.

(*1) For DC input, the input span is the same as the scaling span.



(*2) For DC input, input range low(or high) limit value is the same as scaling low(or high) limit value.

5.4 Auxiliary Function Setting Mode 1

To enter Auxiliary function setting mode 1, press the  key for approx. 3 seconds while holding down the  key.

The set value can be increased or decreased with the  or  key.

Pressing the  key registers the set value, and proceeds to the next setting item.

Character	Name, Function, Setting range	Default value
<i>L o c k</i>	Set Value Lock <ul style="list-style-type: none"> Locks the set value to prevent setting errors. The setting item to be locked differs depending on the selection. When selecting Lock, set the necessary items in the Unlock status, then select Lock 1, Lock 2 or Lock 3. Selection item: <ul style="list-style-type: none"> ---- (Unlock) : All set values can be changed. <i>L o c 1</i> (Lock 1) : None of set values can be changed. <i>L o c 2</i> (Lock 2) : Only SV1 and SV2 can be changed. <i>L o c 3</i> (Lock 3) : All set values except input type can be changed temporarily. However, changed values revert to their previous value after power-off because they are not saved in the non-volatile memory. Do not change any setting item in Auxiliary function setting mode 2. If any item in Auxiliary function setting mode 2 is changed, it will affect other setting items such as SV and Alarm value. Be sure to select Lock 3 when changing the set values frequently via communication function. (If the value set by the communication function is the same as the value before the setting, the value will not be written in non-volatile memory.) 	Unlock
<i>SV H</i> 	SV High Limit <ul style="list-style-type: none"> Sets SV high limit. Setting range: SV low limit to input range high limit value DC input: SV low limit to scaling high limit value (The placement of the decimal point follows the selection) 	1370°C
<i>SV L</i> 	SV Low Limit <ul style="list-style-type: none"> Sets SV low limit. Setting range: Input range low limit value to SV high limit DC input: Scaling low limit value to SV high limit (The placement of the decimal point follows the selection) 	-200°C
<i>SV C</i> 	Sensor Correction <ul style="list-style-type: none"> Sets the sensor correction value. Setting range: -100.0 to 100.0°C (°F) DC input: -1000 to 1000 (The placement of the decimal point follows the selection) 	0.0°C

[Sensor Correction Function]

This corrects the input value from the sensor. When a sensor cannot be set at a location where control is desired, temperatures measured by the sensor may deviate from the temperature in the controlled location. When controlling with plural controllers, sometimes the measured temperatures (input value) do not concur due to difference in sensor accuracy or dispersion of load capacities.

In such a case, the control can be set at the desired temperature by adjusting the input value of sensors. However, it is effective within the input rated range regardless of the sensor correction value.

PV after sensor correction = Current PV + (Sensor correction value)

Character	Name, Function, Setting range	Default value
ㄷㄴㄴ	Communication Protocol <ul style="list-style-type: none"> • Selects the communication protocol. • Available only when Serial communication (option) is added. • Selection item : ㄴㄴㄴ (Shinko protocol), ㄴㄴㄴ (Modbus ASCII mode), ㄴㄴㄴ (Modbus RTU mode) 	Shinko protocol
ㄷㄴㄴ	Instrument Number <ul style="list-style-type: none"> • Sets the instrument number of this unit. (The instrument number should be set individually when communicating by connecting plural instruments in Serial communication. Otherwise communication is impossible.) • Available only when the Serial communication (option) is added • Setting range: 0 to 95 	0
ㄷㄴㄴ	Communication Speed <ul style="list-style-type: none"> • Selects a communication speed equal to that of the host computer. Otherwise communication is impossible. • Available only when Serial communication (option) is added. • Selection item: ㄷㄴㄴ (2400 bps), ㄷㄴㄴ (4800 bps), ㄷㄴㄴ (9600 bps), ㄷㄴㄴ (19200 bps) 	9600 bps
ㄷㄴㄴ	Parity <ul style="list-style-type: none"> • Selects the parity. • Not available if Serial communication (option) is not added or if Shinko protocol is selected during the Communication protocol selection. • Selection item: ㄴㄴㄴ (No parity), ㄷㄴㄴ (Even parity), ㄴㄴㄴ (Odd parity) 	Even parity
ㄷㄴㄴ	Stop Bit <ul style="list-style-type: none"> • Selects the stop bit. • Not available if Serial communication (option) is not added or if Shinko protocol is selected during the Communication protocol selection. • Selection item: ㄷㄴㄴ : 1, ㄷㄴㄴ : 2 	1

5.5 Auxiliary Function Setting Mode 2

To enter Auxiliary function setting mode 2, press the ∇ key for approx. 3 seconds while holding down the \triangle key.

The set value can be increased or decreased by pressing the \triangle or ∇ key.

Pressing the \odot key registers the set value, and proceeds to the next setting item.

If Lock 3 is selected during Set value lock selection, first release Lock 3 to Unlock, then change each set value in Auxiliary function setting mode 2.

Character	Name, Function, Setting range	Default value
ㄷㄴㄴ	Input Type <ul style="list-style-type: none"> • An input type from thermocouple (10 types), RTD (2 types), current (2 types) and voltage (4 types) and $^{\circ}\text{C}/^{\circ}\text{F}$ can be selected. • When changing the input from DC voltage to other inputs, remove the sensor connected to the controller first, then change the input. If the input is changed with the sensor connected, the input circuit may break. 	K (-200 to 1370 $^{\circ}\text{C}$)
ㄷㄴㄴ K	-200 to 1370 $^{\circ}\text{C}$	ㄷㄴㄴ F K -320 to 2500 $^{\circ}\text{F}$
ㄷㄴㄴ K	-199.9 to 400.0 $^{\circ}\text{C}$	ㄷㄴㄴ F K -199.9 to 750.0 $^{\circ}\text{F}$
ㄷㄴㄴ J	-200 to 1000 $^{\circ}\text{C}$	ㄷㄴㄴ F J -320 to 1800 $^{\circ}\text{F}$
ㄷㄴㄴ R	0 to 1760 $^{\circ}\text{C}$	ㄷㄴㄴ F R 0 to 3200 $^{\circ}\text{F}$
ㄷㄴㄴ S	0 to 1760 $^{\circ}\text{C}$	ㄷㄴㄴ F S 0 to 3200 $^{\circ}\text{F}$
ㄷㄴㄴ B	0 to 1820 $^{\circ}\text{C}$	ㄷㄴㄴ F B 0 to 3300 $^{\circ}\text{F}$

$E\Box\Box C$ E	-200 to 800°C	$E\Box\Box F$ E	-320 to 1500°F
$F\Box\Box C$ T	-199.9 to 400.0°C to	$F\Box\Box F$ T	-199.9 to 750.0°F
$n\Box\Box C$ N	-200 to 1300°C	$n\Box\Box F$ N	-320 to 2300°F
$PL2C$ PL-II	0 to 1390°C	$PL2F$ PL-II	0 to 2500°F
$c\Box\Box C$ C(W/Re5-26)	0 to 2315°C	$c\Box\Box F$ C(W/Re5-26)	0 to 4200°F
$Pt\Box C$ Pt100	-199.9 to 850.0°C	$Pt\Box F$ Pt100	-199.9 to 999.9°F
$JPt\Box C$ JPt100	-199.9 to 500.0°C	$JPt\Box F$ JPt100	-199.9 to 900.0°F
$Pt\Box C$ Pt100	-200 to 850°C	$Pt\Box F$ Pt100	-300 to 1500°F
$JPt\Box C$ JPt100	-200 to 500°C	$JPt\Box F$ JPt100	-300 to 900°F
$420A$ 4 to 20 mA DC	-1999 to 9999		
$020A$ 0 to 20 mA DC	-1999 to 9999		
$0\Box 1A$ 0 to 1 V DC	-1999 to 9999		
$0\Box 5A$ 0 to 5 V DC	-1999 to 9999		
$1\Box 5A$ 1 to 5 V DC	-1999 to 9999		
$0\Box 10A$ 0 to 10 V DC	-1999 to 9999		
$4FLH$	Scaling High Limit <ul style="list-style-type: none"> Sets scaling high limit value. Available only for the DC input Setting range: Scaling low limit to Input range high limit value (The placement of the decimal point follows the selection) 	9999	
$4FLL$	Scaling Low Limit <ul style="list-style-type: none"> Sets scaling low limit value. Available only for the DC input Setting range: Input range low limit to scaling high limit value (The placement of the decimal point follows the selection) 	-1999	
$dP\Box\Box$	Decimal Point Place <ul style="list-style-type: none"> Selects the decimal point place. Available only for the DC input Selection item: $\Box\Box\Box 0$: No decimal point $\Box\Box\Box 00$: 1 digit after decimal point $\Box\Box\Box 000$: 2 digits after decimal point $\Box\Box\Box 0000$: 3 digits after decimal point 	No decimal point	
$FILF$	PV Filter Time Constant <ul style="list-style-type: none"> Sets PV filter time constant. If the value is set too large, it affects the control result due to the delay of response. Setting range: 0.0 to 10.0 sec 	0.0 sec	
$oLH\Box$	OUT1 High Limit <ul style="list-style-type: none"> Sets the high limit value for OUT1. Not available if OUT1 is in ON/OFF control Setting range: OUT1 low limit to 100% (Relay contact output, non-contact voltage output) OUT1 low limit to 105% (Current output) 	100%	
$oLL\Box$	OUT1 Low Limit <ul style="list-style-type: none"> Sets low limit value for OUT1. Not available if OUT1 is in ON/OFF control Setting range: 0% to OUT1 high limit (Relay contact output, Non-contact voltage output) -5% to OUT1 high limit (Current output) 	0%	

Character	Name, Function, Setting range	Default value
<i>HY4</i>	OUT1 ON/OFF Hysteresis <ul style="list-style-type: none"> • Sets ON/OFF hysteresis for OUT1. • Available only when OUT1 is in ON/OFF control • Setting range: 0.1 to 100.0°C(°F) DC input: 1 to 1000 (The placement of the decimal point follows the selection.) 	1.0°C
<i>cAct</i>	OUT2 Action Mode <ul style="list-style-type: none"> • Selects OUT2 cooling action from a choice of: Air cooling, oil cooling and water cooling. • Not available if OUT2 is in ON/OFF control or if the Heating/Cooling control option is not added • Selection item: <i>air</i>: Air cooling (linear characteristics) <i>oil</i>: Oil cooling (1.5th power of the linear characteristics) <i>wat</i>: Water cooling (2nd power of the linear characteristics) 	Air cooling
<i>oLHb</i>	OUT2 High Limit <ul style="list-style-type: none"> • Sets the high limit value for OUT2. • Not available if OUT2 is in ON/OFF control or if the Heating/Cooling control option is not added • Setting range: OUT2 low limit to 100% (Relay contact output, non-contact voltage output) OUT2 low limit to 105% (Current output) 	100%
<i>oLLb</i>	OUT2 Low Limit <ul style="list-style-type: none"> • Sets the low limit value for OUT2. • Not available if OUT2 is in ON/OFF control or if the Heating/Cooling control option is not added • Setting range: 0% to OUT2 high limit (Relay contact output, Non-contact voltage output) -5% to OUT2 high limit (Current output) 	0%
<i>db</i>	Overlap/Dead Band <ul style="list-style-type: none"> • Sets the Overlap or Dead band for OUT1 and OUT2. + Set value: Dead band - Set value: Overlap band • Available only when the Heating/Cooling control option is added • Setting range: -100.0 to 100.0°C (°F) DC input: -1000 to 1000 (The placement of the decimal point follows the selection) 	0.0°C
<i>HY4b</i>	OUT2 ON/OFF Hysteresis <ul style="list-style-type: none"> • Sets ON/OFF hysteresis for OUT2. • Available when OUT2 is in ON/OFF control and when the Heating/Cooling control option is added • Setting range: 0.1 to 100.0°C (°F) DC input: 1 to 1000 (The placement of the decimal point follows the selection) 	1.0°C

Character	Name, Function, Setting range	Default value
<i>AL 1F</i>	A1 Type <ul style="list-style-type: none"> Selects Alarm 1 (A1) type. (See Section 7.5 on pages 34, 35.) Note: If A1 type is changed, the A1 value defaults to 0 (0.0). Therefore it is necessary to set it again. Selection item: <ul style="list-style-type: none"> ----: No alarm action <i>H</i><input type="checkbox"/><input type="checkbox"/><input type="checkbox"/><input type="checkbox"/> <i>L</i><input type="checkbox"/><input type="checkbox"/><input type="checkbox"/><input type="checkbox"/> <i>HL</i><input type="checkbox"/><input type="checkbox"/><input type="checkbox"/><input type="checkbox"/> <i>u l d</i><input type="checkbox"/><input type="checkbox"/><input type="checkbox"/><input type="checkbox"/> <i>PH</i><input type="checkbox"/><input type="checkbox"/> <i>-PH</i><input type="checkbox"/><input type="checkbox"/> <i>H</i><input type="checkbox"/><input type="checkbox"/><i>L</i> <i>L</i><input type="checkbox"/><input type="checkbox"/><i>L</i> <i>HL</i><input type="checkbox"/><input type="checkbox"/><i>L</i> Process high alarm Process low alarm High limit alarm with standby Low limit alarm with standby High/Low limits alarm with standby 	No alarm action
<i>AL 2F</i>	A2 Type <ul style="list-style-type: none"> Selects Alarm 2 (A2) type. (See Section 7.5 on pages 34, 35.) Available only when the A2 option is added Note: If A2 type is changed, the A2 value defaults to 0 (0.0). Therefore it is necessary to set it again. Selection items are the same as those of A1 type. 	No alarm action
<i>A 1L \bar{a}</i>	A1 Action Energized/De-energized <ul style="list-style-type: none"> Selects A1 action Energized/De-energized. (See Energized/De-energized function on p.27) Not available if No alarm action is selected during A1 type selection Selection item: <i>on</i><input type="checkbox"/><input type="checkbox"/><input type="checkbox"/><input type="checkbox"/> (Energized), <i>-E</i><input type="checkbox"/><input type="checkbox"/><input type="checkbox"/><input type="checkbox"> (De-energized)</input> 	Energized
<i>A 2L \bar{a}</i>	A2 Action Energized/De-energized <ul style="list-style-type: none"> Selects A2 action Energized/De-energized. (See Energized/De-energized function on p.27) Not available if No alarm action is selected during A2 type selection or if A2 (option) is not added Selection items are the same as those of A1 action Energized/De-energized. 	Energized
<i>A 1HY</i>	A1 Hysteresis <ul style="list-style-type: none"> Sets A1 hysteresis. Not available if No alarm action is selected during A1 type selection Setting range: Thermocouple, RTD input: 0.1 to 100.0°C DC input: 1 to 1000 (The placement of the decimal point follows the selection.) 	1.0°C
<i>A 2HY</i>	A2 Hysteresis <ul style="list-style-type: none"> Sets A2 hysteresis. Not available if No alarm action is selected during A2 type selection or if A2 (option) is not added Setting range is the same as those of the A1 hysteresis setting. 	1.0°C
<i>A 1dY</i>	A1 Action Delay Timer <ul style="list-style-type: none"> Sets A1 action delay timer. When setting time has elapsed after the input enters the alarm output range, the alarm is activated. Not available if No alarm action is selected during A1 type selection Setting range: 0 to 9999 seconds 	0 sec

Character	Name, Function, Setting range	Default value
<i>A2d4</i>	A2 Action Delay Timer <ul style="list-style-type: none"> • Sets A2 action delay timer. When setting time has elapsed after the input enters the alarm output range, the alarm is activated. • Not available if No alarm action is selected during A2 type selection or if A2 (option) is not added • Setting range: 0 to 9999 seconds 	0 sec
<i>conf</i>	Direct/Reverse Control Action <ul style="list-style-type: none"> • Selects either Direct (Cooling) or Reverse (Heating) control action. • Selection item: <i>HEAT</i>: Reverse (Heating) control <i>COOL</i>: Direct (Cooling) control 	Reverse (Heating)
<i>AT_b</i>	AT Bias <ul style="list-style-type: none"> • Sets the bias value when AT is performing. (See Section 8.2 on pages 36, 37.) • Not available for DC input • Setting range: 0 to 50°C (0 to 100°F) With a decimal point: 0.0 to 50.0°C (0.0 to 100.0°F) 	20°C
<i>4b_b</i>	SVTC Bias <ul style="list-style-type: none"> • SV adds SVTC bias value to the value received by the digital transmission. • Available only when Serial communication (option) is added • Setting range: Converted value of $\pm 20\%$ of the input span DC input: Converted value of $\pm 20\%$ of the scaling span (The placement of the decimal point follows the selection.) However, the negative minimum value is -1999, -199.9, -19.99 or -1.999. 	0
<i>EOUF</i>	Output Status when Input Abnormal <ul style="list-style-type: none"> • Selects the output status of OUT1 and OUT2 (D□ option) when DC input is Overscale or Underscale. • Available only for Current output with DC input • Selection item: <i>OFF</i>□: Outputs OFF (4mA) or OUT1 (OUT2) low limit. <i>ON</i>□: Outputs a value between OFF (4mA) and ON (20mA) or between OUT1 (OUT2) low limit value and OUT1 (OUT2) high limit value, depending on a deviation. 	Outputs OFF (4mA) or OUT1 (OUT2) low limit.
<i>MANU</i>	OUT/OFF Key Function <ul style="list-style-type: none"> • Selects whether the OUT/OFF Key is used for “Control output OFF function” or for “Auto/Manual control function”. • Selection item: <i>OFF</i>□: Control output OFF function <i>MANU</i>: Auto/Manual control function 	Control output OFF

Alarm Action Energized/De-energized Function

[If the alarm action Energized is selected]

When the alarm output indicator is lit, the alarm output (terminals 15-16 or 17-18) is conducted (ON). When the alarm output indicator is unlit, the alarm output is not conducted (OFF). See (Fig. 5.5-1).

[If the alarm action De-energized is selected]

When the alarm output indicator is lit, the alarm output (terminals 15-16 or 17-18) is not conducted (OFF). When the alarm output indicator is unlit, the alarm output is conducted (ON). See (Fig. 5.5-2).

High limit alarm (When Energized is set) High limit alarm (When De-energized is set)

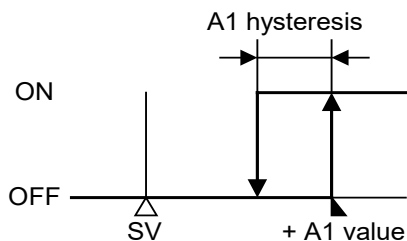

(Fig. 5.5-1)

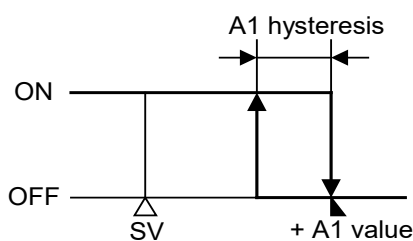

(Fig. 5.5-2)

5.6 Control Output OFF Function

- A function to pause the control action or turn the control output of the unused instrument of the plural units OFF even if the power to the instrument is supplied.
 - Pressing the ① key (OUT/OFF Key) for approx. 1 sec from any mode turns the control output OFF.
- [OFF] is indicated on the PV display while this function is working.
- Pressing the ① key again for approx. 1 sec cancels the Control output OFF function.
- Once the Control output OFF function is enabled, the function cannot be released even if the power to the instrument is turned OFF and ON again.
- To cancel the function, press the ① key again for approx. 1 second.

5.7 Auto/Manual Control Switching

- Select "Auto/Manual control function" during the "OUT/OFF Key function" selection in Auxiliary function setting mode 2.
- Press the ① key in the PV/SV display mode. Auto/Manual control can be switched.
- If the control action is changed from automatic to manual control, the MV on the SV display flashes. The control can be performed manually by increasing or decreasing the MV on the SV display with the \triangle or ∇ key.
- By pressing the ① key again, the unit reverts to the PV/SV display mode (automatic control).
- When the power supply to the instrument is turned ON, automatic control starts.
- When control is changed from automatic to manual and vice versa, the balanceless-bumpless function works to prevent sudden change of MV.
 - If Auto/Manual control function is selected, Control output OFF function is disabled.

5.8 MV Indication

- If the ⓪ key is pressed for approx. 3 seconds in the PV/SV display mode, the MV will be indicated on the SV display. During MV indication, the 2nd decimal point from the right on the SV display flashes at a cycle of 500ms.
- By pressing the ⓪ key again, the unit reverts to the PV/SV display mode.

6. Operation

After the controller is mounted to the control panel and wiring is completed, operate the controller following the procedures below.

(1) Turn the power supply to the JCM-33A ON.

With thermocouple and RTD input, sensor input characters and temperature unit are indicated on the PV display, and the input range high limit value is indicated on the SV display for approx. 3 seconds after the power is switched ON. See (Table 6-1).

With the DC input, sensor input characters are indicated on the PV display, and scaling high limit value is indicated on the SV display for approx. 3 seconds after the power is switched ON. See (Table 6-1).

However, if the scaling high limit value has been changed during the Scaling high limit setting, the changed value is indicated on the SV display.

During this time, all outputs and the LED indicators are in OFF status.

After that, control starts indicating the PV on the PV display and SV1 on the SV display. When the Control output OFF function is working, [OFF] is indicated on the PV display.

(Table 6-1)

Sensor input	°C		°F	
	PV display	SV display	PV display	SV display
K	tc C	1370	tc F	2500
	tc C	4000	tc F	7500
J	jc C	1000	jc F	1800
R	rc C	1760	rc F	3200
S	sc C	1760	sc F	3200
B	bc C	1820	bc F	3300
E	ec C	0800	ec F	1500
T	tc C	4000	tc F	7500
N	nc C	1300	nc F	2300
PL-II	PL2C	1390	PL2F	2500
C (W/Re5-26)	cc C	2315	cc F	4200
Pt100	pt C	8500	pt F	9999
	pt C	0850	pt F	1500
JPt100	JPtC	5000	JPtF	9000
	JPtC	0500	JPtF	0900
4 to 20 mA DC	420A	Scaling high limit value		
0 to 20 mA DC	020A			
0 to 1 V DC	001B			
0 to 5 V DC	005B			
1 to 5 V DC	105B			
0 to 10 V DC	010B			

(2) Input each set value.

Input each set value, referring to "5. Setup".

(3) Turn the load circuit power ON.

Control action starts so as to keep the control target at the SV.

7. Action Explanation

7.1 OUT1 Action

	Heating (reverse) action			Cooling (direct) action		
Control action						
Relay contact output R/ <input type="checkbox"/>						
Non-contact voltage output S/ <input type="checkbox"/>						
Current output A/ <input type="checkbox"/>						
Indicator (OUT1) Green						

: Turns ON (lit) or OFF (unlit).

7.2 Heater Burnout Alarm Action (Option)

Heater burnout alarm action		
Heater burnout alarm output		
Indicator (HB) red	Lit Unlit	

Heater burnout alarm output terminals differs depending on the added options.

When A2 output (option) is added, use terminals 8 and 9 for the Heater burnout alarm.

When Heating/Cooling control (option) is added, use terminals 17 and 18 for the Heater burnout alarm.

7.3 OUT1 ON/OFF Control Action

	Heating (reverse) action		Cooling (direct) action	
Control action				
Relay contact output R/□				
Non-contact voltage output S/□				
Current output A/□				
Indicator (OUT1) Green				

: Turns ON (lit) or OFF (unlit).

7.4 OUT2 (Heating/Cooling Control) Action (Option)

Control action			
Relay contact output (OUT1) R/□	<p>Cycle action is performed according to deviation.</p>		
Relay contact output (OUT2) DR	<p>Cycle action is performed according to deviation.</p>		
Non-contact voltage output (OUT1) S/□	<p>Cycle action is performed according to deviation.</p>		
Non-contact voltage output (OUT2) DS	<p>Cycle action is performed according to deviation.</p>		
Current output (OUT1) A/□	<p>Changes continuously according to deviation.</p>		
Current output (OUT2) DA	<p>Changes continuously according to deviation.</p>		
Indicator (OUT1) Green			
Indicator (OUT2) Yellow			

: Turns ON (lit) or OFF (unlit).

————— : Represents Heating control action.

- - - - - : Represents Cooling control action.

When Setting Dead Band

Control action			
Relay contact output (OUT1) R/□	<p>Cycle action is performed according to deviation.</p>		
Relay contact output (OUT2) DR	<p>Cycle action is performed according to deviation.</p>		
Non-contact voltage output (OUT1) S/□	<p>Cycle action is performed according to deviation.</p>		
Non-contact voltage output (OUT2) DS	<p>Cycle action is performed according to deviation.</p>		
Current output (OUT1) A/□	<p>Changes continuously according to deviation.</p>		
Current output (OUT2) DA	<p>Changes continuously according to deviation.</p>		
Indicator (OUT1) Green			
Indicator (OUT2) Yellow			

: Turns ON (lit) or OFF (unlit).

————— : Represents Heating control action.

----- : Represents Cooling control action.

When Setting Overlap Band

Control action			
Relay contact output (OUT1) R/□	<p>Cycle action is performed according to deviation.</p>		
Relay contact output (OUT2) DR	<p>Cycle action is performed according to deviation.</p>		
Non-contact voltage output (OUT1) S/□	<p>Cycle action is performed according to deviation.</p>		
Non-contact voltage output (OUT2) DS	<p>Cycle action is performed according to deviation.</p>		
Current output (OUT1) A/□	<p>Changes continuously according to deviation.</p>		
Current output (OUT2) DA	<p>Changes continuously according to deviation.</p>		
Indicator (OUT1) Green	<p>Lit Unlit</p>		
Indicator (OUT2) Yellow	<p>Unlit Lit</p>		

: Turns ON (lit) or OFF (unlit).

————— : Represents Heating control action.

- - - - - : Represents Cooling control action.

7.5 A1 and A2 Actions

	High limit alarm	Low limit alarm
Alarm action		
Alarm output		
	High/Low limits alarm	High/Low limit range alarm
Alarm action		
Alarm output		
	Process high alarm	Process low alarm
Alarm action		
Alarm output		
	High limit alarm with standby	Low limit alarm with standby
Alarm action		
Alarm output		

High/Low limits alarm with standby	
Alarm action	
Alarm output	

 : A1 output terminals 15 and 16 are closed (ON).

 : A1 output terminals 15 and 16 are closed (ON) or opened (OFF).

 : A1 output terminals 15 and 16 are opened (OFF).

 : Standby functions.

For A2 output, terminals 17 and 18 are used.

The A1 and A2 indicators light when their output terminals are closed (ON), and go off when their output terminals are opened (OFF).

8. Control Action Explanations

8.1 PID

(1) Proportional Band (P)

Proportional action is the action which the control output varies in proportion to the deviation between the SV and the PV.

If the proportional band is narrowed, even if the output changes by a slight variation of the PV, better control results can be obtained as the offset decreases.

However, if the proportional band is narrowed too much, even slight disturbances may cause variation in the PV, control action changes to ON/OFF action and the so-called hunting phenomenon occurs.

Therefore, when the PV comes to the balanced position near the SV and a constant temperature is maintained, the most suitable value is selected by gradually narrowing the proportional band while observing the control results.

(2) Integral Time (I)

Integral action is used to eliminate offset. When the integral time is shortened, the returning speed to the set point is accelerated. However, the cycle of oscillation is also accelerated and control becomes unstable.

(3) Derivative Time (D)

Derivative action is used to restore the change in the PV according to the rate-of-change. It reduces the amplitude of overshoot and undershoot width.

If the derivative time is shortened, the restoring value becomes small, and if the derivative time is extended, an excessive returning phenomenon may occur and the control system may oscillate.

8.2 AT of This Controller

In order to decide each value of P, I, D and ARW automatically, the AT process should be made to fluctuate to obtain an optimal value.

For DC input, the AT process will fluctuate around the SV regardless of the 3 conditions below.



Notice

- Perform the AT during the trial run.
- During AT, none of the setting items can be set.
- If power failure occurs during AT, the AT stops.
- Sometimes the AT process will not fluctuate if AT is performed at or near room temperature. Therefore AT might not finish normally.

[1] In the case of a large difference between the SV and PV as the temperature is rising.

When AT bias is set to 20°C, the AT process will fluctuate at the temperature 20°C lower than the SV.

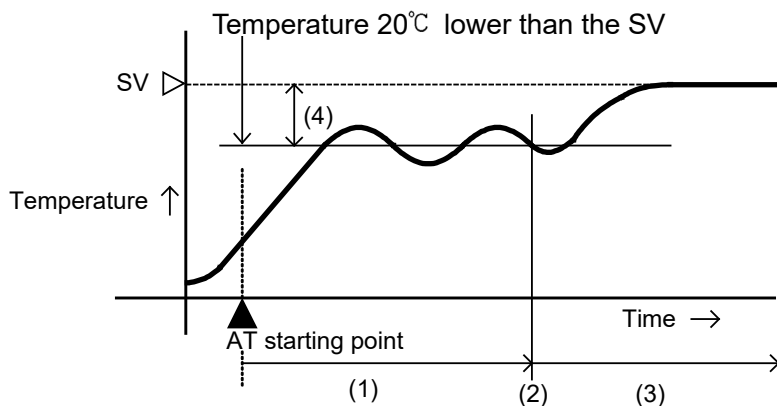

- (1) Calculating PID constant
- (2) PID constant calculated
- (3) Controlled by the PID constant set by AT
- (4) AT bias value

(Fig. 8.2-1)

[2] In the case of stable control or when control temperature is within $SV \pm 20^\circ\text{C}$
 The AT process will fluctuate around the SV.

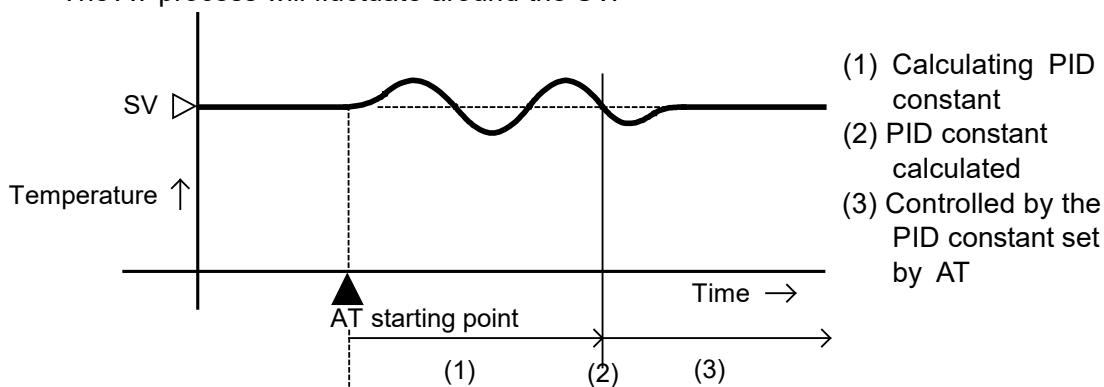

(Fig. 8.2-2)

[3] In the case of a large difference between the SV and PV as the temperature is falling
 When AT bias is set to 20°C , the AT process will fluctuate at the temperature 20°C higher than the SV.

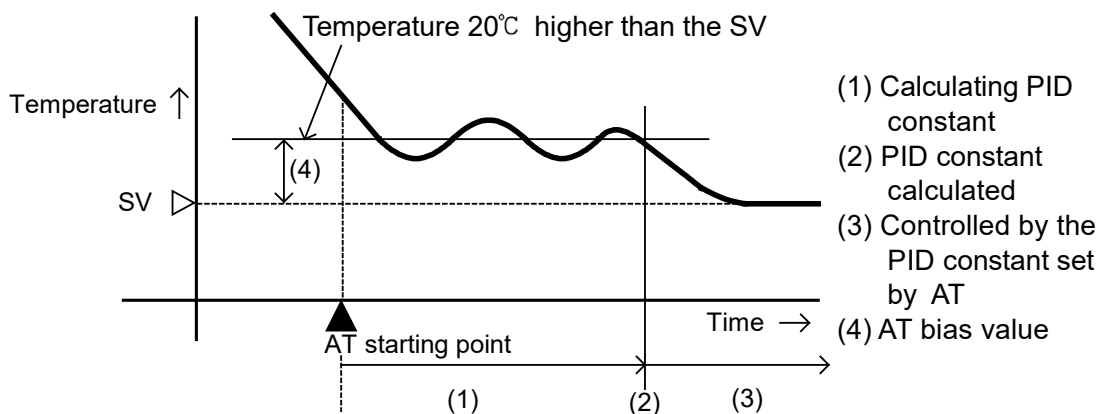

(Fig. 8.2-3)

8.3 Auto-reset (Offset Correction)

Auto-reset is performed to correct the offset at the point at which PV indication is stabilized within the proportional band during the PD action.

Since the corrected value is internally memorized, it is not necessary to perform the auto-reset again as long as the process is the same.

However, when OUT1 proportional band is set to 0 or 0.0, the corrected value is cleared.

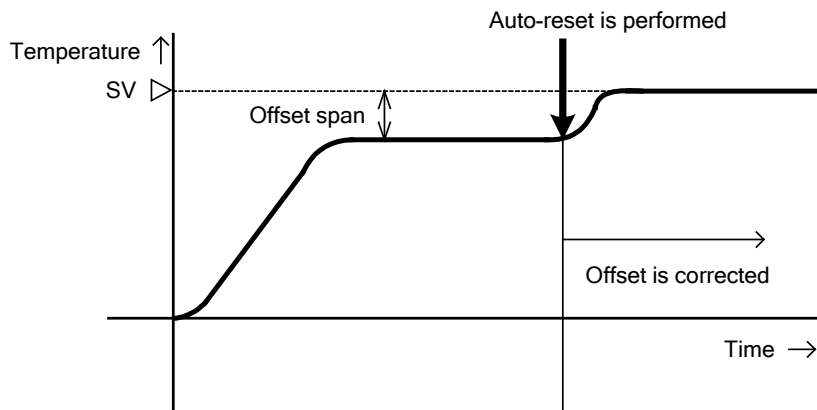

(Fig. 8.3-1)

9. Specifications

9.1 Standard Specifications

Mounting : Flush
Setting : Membrane sheet key
Display

PV display : Red LED 4 digits, character size, 14.3 x 8 (H x W) mm
SV display : Green LED 4 digits, character size, 10 x 5.5 (H x W) mm

Accuracy (Setting, Indication)

Thermocouple : Within $\pm 0.2\%$ of each input span ± 1 digit or within $\pm 2^{\circ}\text{C}$ (4°F), whichever is greater
However, R, S input, 0 to 200°C (0 to 400°F): Within $\pm 6^{\circ}\text{C}$ (12°F)
B input, 0 to 300°C (0 to 600°F): Accuracy is not guaranteed.
K, J, E, T, N input, less than 0°C (32°F): Within $\pm 0.4\%$ of each input span ± 1 digit

RTD : Within $\pm 0.1\%$ of each input span ± 1 digit or within $\pm 1^{\circ}\text{C}$ (2°F), whichever is greater

Voltage, Current: Within $\pm 0.2\%$ of each input span ± 1 digit

Input sampling period : 250 ms

Input

Thermocouple : K, J, R, S, B, E, T, N, PL-II, C (W/Re5-26)
External resistance, 100 Ω or less, however, for B, 40 Ω or less

RTD : Pt100, JPt100, 3-wire system
Allowable input lead wire resistance, 10 Ω or less per wire

Current : 0 to 20 mA DC, 4 to 20 mA DC
Input impedance, 50 Ω
[50 Ω shunt resistor (sold separately) must be connected between input terminals.]
Allowable input current, 50 mA or less [When 50 Ω shunt resistor (sold separately) is used]

Voltage : 0 to 1 V DC;
Input impedance, 1 M Ω or more
Allowable input voltage, 5 V or less
Allowable signal source resistance, 2 k Ω or less
0 to 5 V DC, 1 to 5 V DC, 0 to 10 V DC;
Input impedance, 100 k Ω or more
Allowable input voltage, 15 V or less
Allowable signal source resistance, 100 Ω or less

Control output (OUT1)

Relay contact : 1a1b
Control capacity: 3 A 250 V AC (resistive load)
1 A 250 V AC (inductive load $\cos\phi=0.4$)
Electrical life: 100,000 cycles

Non-contact voltage (For SSR drive):
12₀⁺² V DC Max 40 mA (short circuit protected)
Number of units when connecting Shinko SSR in parallel:
SA-400 series: 5 units

Current : 4 to 20 mA DC
Load resistance, Max 550 Ω

A1 output

When A1 action is set as Energized, the alarm action point is set by the \pm deviation from the SV (except Process alarm).

When the input goes outside the range, the output turns ON or OFF (in the case of High/Low limit range alarm).

When the alarm action is set as De-energized, the output acts conversely.

Setting accuracy : The same as the Indication accuracy
 Action : ON/OFF action
 Hysteresis : Thermocouple, RTD input: 0.1 to 100.0°C (°F)
 Voltage, Current input: 1 to 1000 (The placement of the decimal point follows the selection.)
 Output : Relay contact, 1a
 Control capacity: 3 A 250 V AC (resistive load)
 Electrical life: 100,000 cycles

Control action

- PID control (with AT function)
- PI control: When derivative time is set to 0
- PD control (with auto-reset function): When integral time is set to 0
- P control (with auto-reset function): When integral and derivative times are set to 0
- ON/OFF control: When OUT1 proportional band is set to 0

OUT1 proportional band (P): Thermocouple: 0 to 1000°C (0 to 2000°F)
 RTD: 0.0 to 999.9°C (0.0 to 999.9°F)
 Voltage, Current: 0.0 to 100.0%
 [ON/OFF control when set to 0°C(°F), 0.0°C(°F) or 0.0%]
 Integral time (I): 0 to 1000 sec (off when set to 0)
 Derivative time (D): 0 to 300 sec (off when set to 0)
 OUT1 proportional cycle: 1 to 120 sec (Not available for the current output)
 ARW: 0 to 100%
 OUT1 hysteresis: Thermocouple, RTD input: 0.1 to 100.0°C (°F)
 Voltage, Current input: 1 to 1000 (The placement of the decimal point follows the selection.)

Supply voltage: 100 to 240 V AC 50/60 Hz, 24 V AC/DC 50/60 Hz

Allowable voltage fluctuation range:

100 to 240 V AC: 85 to 264 V AC
 24 V AC/DC: 20 to 28 V AC/DC

Ambient temperature: 0 to 50°C (32 to 122°F)

Ambient humidity: 35 to 85%RH (non-condensing)

Power consumption: Approx. 8 VA

Circuit insulation configuration:

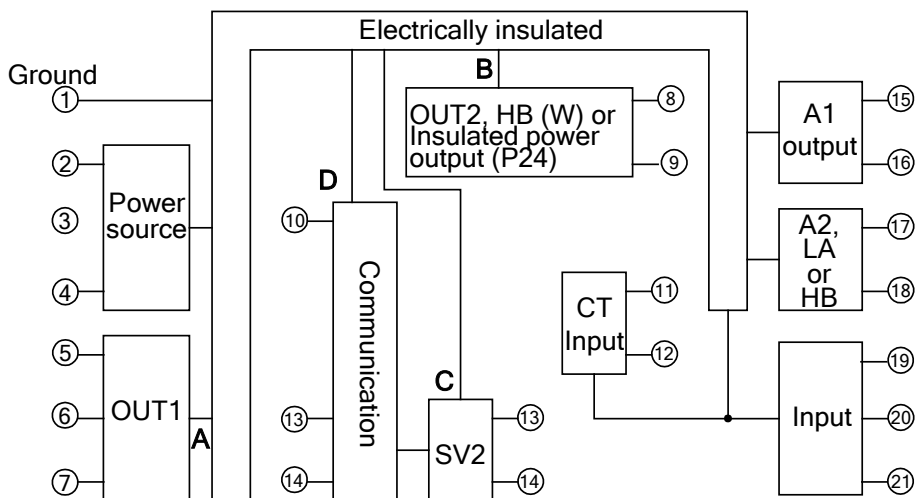

- When OUT1 is non-contact voltage or current output, and when OUT2 is Non-contact voltage or current output, A is not electrically insulated from B.
- When OUT1 is non-contact voltage or current output, A is not electrically insulated from C, and A is not electrically insulated from D. When OUT2 is non-contact voltage or current output, B is not electrically insulated from C, and B is not electrically insulated from D.

Insulation resistance

10 MΩ or more, at 500 V DC for other combinations except the above mentioned

Dielectric strength

Between input terminal and ground terminal, 1.5 kV AC for 1 minute

Between input terminal and power terminal, 1.5 kV AC for 1 minute

Between output terminal and ground terminal, 1.5 kV AC for 1 minute

Between output terminal and power terminal, 1.5 kV AC for 1 minute

Between power terminal and ground terminal, 1.5 kV AC for 1 minute

Weight: Approx. 300 g

External dimensions: 72 x 72 x 100 mm (W x H x D)

Material: Case: Flame-resistant resin

Color: Case: Light gray

Attached function

[Sensor correction function]

[Set value lock function]

[Burnout]

When the thermocouple or RTD input is burnt out, OUT1 is turned OFF (for current output type, OUT1 low limit value) and the PV display flashes " _ _ _ _ _".

[Self-diagnosis]

The CPU is monitored by a watchdog timer, and if an abnormal status is found on the CPU, the controller is switched to warm-up status.

[Automatic cold junction temperature compensation](Thermocouple input type)

This detects the temperature at the connecting terminal between the thermocouple and the instrument, and always maintains it at the same status as if the reference junction location temperature was at 0°C (32°F).

[Power failure countermeasure]

The setting data is backed up in non-volatile IC memory.

[Indication and output when input is abnormal]

Output status when input abnormal (*1)	Contents and Indication	Output status			
		OUT1		OUT2	
		Direct action	Reverse action	Direct action	Reverse action
ON□□□	Overscale Measured value has exceeded Indication range high limit value. " _ _ _ _ _" flashes.	ON (20 mA) or OUT1 high limit value (*2)	OFF(4 mA) or OUT1 low limit value	OFF(4 mA) or OUT2 low limit value	ON(20 mA) or OUT2 high limit value (*2)
OFF□□□		OFF (4mA) or OUT1 low limit value			OFF(4 mA) or OUT2 low limit value
ON□□□	Underscale Measured value has dropped below Indication range low limit value. " _ _ _ _ _" flashes.	OFF (4mA) or OUT1 low limit value	ON (20 mA) or OUT1 high limit value (*2)	ON (20 mA) or OUT2 high limit value (*2)	OFF(4 mA) or OUT2 low limit value
OFF□□□			OFF(4 mA) or OUT1 low limit value	OFF(4 mA) or OUT2 low limit value	

(*1) This is only available for DC input and when OUT1 is current output type.

If OUT1 is not current output, the output status will be the same one as when OFF□□□ is selected during "Output status when input abnormal".

For manual control, the preset MV (manipulated variable) is outputted.

(*2) Outputs a value between OFF (4 mA) and ON (20 mA) or between OUT1 (or OUT2) low limit value and OUT1 (or OUT2) high limit value, depending on deviation.

Thermocouple, RTD input

Input	Input range	Indication range	Control range
K, T	-199.9 to 400.0°C	-199.9 to 450.0°C	-205.0 to 450.0°C
	-199.9 to 750.0°F	-199.9 to 850.0°F	-209.0 to 850.0°F
Pt100	-199.9 to 850.0°C	-199.9 to 900.0°C	-210.0 to 900.0°C
	-200 to 850°C	-210 to 900°C	-210 to 900°C
	-199.9 to 999.9°F	-199.9 to 999.9°F	-211.0 to 1099.9°F
JPt100	-300 to 1500°F	-318 to 1600°F	-318 to 1600°F
	-199.9 to 500.0°C	-199.9 to 550.0°C	-206.0 to 550.0°C
	-200 to 500°C	-207 to 550°C	-207 to 550°C
	-199.9 to 900.0°F	-199.9 to 999.9°F	-211.0 to 999.9°F
	-300 to 900°F	-312 to 1000°F	-312 to 1000°F

Indication range and Control range for thermocouple inputs other than the above:
Input range low limit value -50°C (100°F) to Input range high limit value +50°C (100°F)

• DC input (DC voltage, current input)

Indication range : [Scaling low limit value – Scaling span x 1%] to [Scaling high limit value + Scaling span x 10%]

However, if the input value is out of the range -1999 to 9999, the PV display flashes “- - - -” or “- - - -”.

Control range : [Scaling low limit value – Scaling span x 1%] to [Scaling high limit value + Scaling span x 10%]

- **DC input disconnection**: When DC input is disconnected, the PV display flashes “- - - -” for 4 to 20 mA DC and 1 to 5 V DC inputs, and “- - - -” for 0 to 1 V DC input.

For 0 to 20 mA DC, 0 to 5 V DC and 0 to 10 V DC inputs, the PV display indicates the value corresponding with 0 mA or 0 V input.

[Warm-up indication]

With thermocouple and RTD input, for approx. 3 seconds after the power is switched ON, sensor input characters and temperature unit are indicated on the PV display, and the input range high limit value is indicated on the SV display. With the DC input, for approx. 3 seconds after the power is switched ON, sensor input characters are indicated on the PV display, and scaling high limit value is indicated on the SV display.

(However, if the scaling high limit value has been changed during the Scaling high limit setting, the changed value will be indicated on the SV display.)

[Auto/Manual control switching]

If “Auto/Manual control function” is selected during OUT/OFF Key function selection, automatic control can be switched to manual control and vice versa by pressing the ① key (OUT/OFF Key) in the PV/SV display mode.

If the control action is changed from automatic to manual control, the MV on the SV display flashes.

The control can be performed manually by increasing or decreasing the MV on the SV display with the △ or ▽ key.

By pressing the ① key again, the unit reverts to the PV/SV display mode (automatic control)

When the power supply to the instrument is turned ON, automatic control starts.

When the control action is changed from automatic to manual control and vice versa, the balanceless-bumpless function works to prevent sudden change of MV.

Accessories:

Instruction manual: 1 copy

Screw type mounting brackets: 1 set

CT (current transformer)

CTL-6S [W (5 A, 10 A, 20 A) option]: 1 piece

CTL-12-S36-10L1U [W (50 A) option]: 1 piece

Terminal cover: 1 piece (when TC option is added)

9.2 Optional Specifications

Alarm 2 (option code: A2)

When A2 action is set as Energized, the alarm action point is set by the \pm deviation from the SV (except Process alarm).

When the input goes outside the range, the output turns ON or OFF (in the case of High/Low limit range alarm).

When the alarm action is set as De-energized, the output acts conversely.

When A2 and LA options are added together, they utilize common output terminals.

Setting accuracy: The same as the Indication accuracy

Action: ON/OFF action

Hysteresis: Thermocouple, RTD input: 0.1 to 100.0°C (°F)

Voltage, Current input: 1 to 1000 (The placement of the decimal point follows the selection.)

Output: Relay contact, 1a

Control capacity: 3 A 250 V AC (resistive load)

Electrical life: 100,000 cycles

Heater burnout alarm (option code: W)

Watches the heater current with CT (current transformer), and detects the heater burnout.

Heater burnout alarm is activated when sensor is burnt out or when indication is Overscale or Underscale.

This option cannot be added to the current output type.

Heater rated current: 5 A, 10 A, 20 A, 50 A, Must be specified.

Setting accuracy: Within $\pm 5\%$ of heater rated current

Action: ON/OFF action

Output: Relay contact, 1a

Control capacity: 3 A 250 V AC (resistive load)

Electrical life: 100,000 cycles

Heating/Cooling control (OUT2) (option code: DR, DS, DA)

OUT2 proportional band: 0.0 to 10.0 times OUT1 proportional band
(ON/OFF control when set to 0.0)

OUT2 integral time: The same as that of OUT1

OUT2 derivative time: The same as that of OUT1

OUT2 proportional cycle: 1 to 120 seconds

Overlap/Dead band:

Thermocouple, RTD input: -100.0 to 100.0°C (°F)

DC voltage, current input: -1000 to 1000 (The placement of the decimal point follows the selection.)

OUT2 ON/OFF hysteresis

Thermocouple, RTD input: 0.1 to 100.0°C (°F)

DC voltage, current input: 1 to 1000 (The placement of the decimal point follows the selection.)

Control output (OUT2) (for SSR drive):

Relay contact output: 1a

Control capacity: 3 A 250 V AC (resistive load)

1 A 250 V AC (inductive load $\cos\phi=0.4$)

Electrical life: 100,000 cycles

Non-contact voltage output (for SSR drive):

12_0^{+2} V DC Max 40 mA (short circuit protected)

Current output: 4 to 20 mA DC

Load resistance, Max 550 Ω

OUT2 action mode selection:

One cooling mode can be selected by keypad from the following.

Air cooling (Linear characteristics)

Oil cooling (1.5th power of the linear characteristics)

Water cooling (2nd power of the linear characteristics)

Serial communication (option code: C5)

The following operations are performed from an external computer.

- (1) Reading and setting of the SV, PID and various set values
- (2) Reading of the PV and action status
- (3) Function change

Communication interface: EIA RS-485

Communication method : Half-duplex communication

Synchronization method: Start-stop synchronization

Communication speed: 2400/4800/9600/19200 bps (Selectable by keypad)

Parity: Even/Odd/No parity (Selectable by keypad)

Stop bit: 1 or 2 (Selectable by keypad)

Data format:

Communication protocol	Shinko protocol	Modbus ASCII	Modbus RTU
Start bit	1	1	1
Data bit	7	7	8
Parity	Even	Selectable (Even)	Selectable (No parity)
Stop bit	1	Selectable (1)	Selectable (1)

Data bit is automatically selected upon selecting the communication protocol.

() shows basic set value.

Digital external setting:

Receives digital set value from Shinko programmable controller (with SVTC option).

[Set value lock of the JCM-33A must be set to Lock 3.]

When SV data from Shinko programmable controller is larger than SV high limit or smaller than SV low limit, the JCM-33A ignores the value and controls with the SV high limit or SV low limit.

Loop break alarm (option code: LA)

Detects the breaking status on the loop such as heater burnout, sensor burnout or actuator trouble.

If [LA] and [A2] options are added together, they utilize the same output terminals.

Setting range : Loop break alarm time: 0 to 200 minutes

Loop break alarm span:

Thermocouple, RTD input: 0 to 150°C (°F), 0.0 to 150.0°C (°F),

DC voltage, current input: 0 to 1500 (The placement of the decimal point follows the selection.)

Output: Relay contact, 1a, 3 A 250 V AC (Resistive load)

Electrical life: 100,000 cycles

Insulated power output (option code: P24)

Output voltage: 24±3 V DC (when load current is 30mA)

Ripple voltage: Within 200 mV (when load current is 30mA)

Maximum load current: 30 mA

Color Black (option code: BK)

Front panel frame, case: Black

Terminal cover (option code: TC)

Electrical shock protection terminal cover

Drip-proof/Dust-proof (option code: IP)

Drip-proof/Dust-proof specification, IP54 (only for the front panel)

9.3 Option Combinations

	A2	LA	W	D□	P24	C5	BK	TC	IP
Combination 1	O	O	O	–	–	O	O	O	O
Combination 2	O	O	–	O	–	O	O	O	O
Combination 3	–	–	O	O	–	O	O	O	O
Combination 4	O	O	–	–	O	O	O	O	O
Combination 5	O	O	O	–	–	–	O	O	O
Combination 6	O	O	–	O	–	–	O	O	O
Combination 7	–	–	O	O	–	–	O	O	O
Combination 8	O	O	–	–	O	–	O	O	O

D□: DR, DS, DA

O: Available –: Unavailable

10. Troubleshooting

If any malfunctions occur, refer to the following items after checking that power is being supplied to the controller.



Warning

Turn the power supply to the instrument off before wiring or checking. Working on or touching the terminal with the power switched on may result in severe injury or death due to Electric Shock.

Indication

Problem	Presumed cause and solution
The PV display is indicating [□FF□].	<ul style="list-style-type: none"> Control output OFF function is working. Press the ⓐ key (OUT/OFF Key) for approx. 1 second to release the function.
[- - - -] is flashing on the PV display.	<ul style="list-style-type: none"> Burnout of thermocouple, RTD or disconnection of DC voltage (0 to 1 V DC) Replace each sensor. How to check sensor burnout [Thermocouple] If the input terminals of the instrument are shorted, and if approximate room temperature is indicated, the instrument is likely to be operating normally, however, the sensor may be burnt out. [RTD] If approximate 100 Ω resistance is connected to the input terminal between A-B of the instrument and between B-B is shorted, and if a value around 0°C (32°F) is indicated, the instrument is likely to be operating normally, however, the sensor may be burnt out. [DC voltage (0 to 1 V DC)] If the input terminals of the instrument are shorted, and if scaling low limit value is indicated, the instrument is likely to be operating normally, however, the signal wire may be disconnected. Check whether the input terminal of thermocouple, RTD or DC voltage (0 to 1 V DC) is securely mounted to the controller terminals. Ensure that the sensor terminals are securely connected to the controller terminals.

Problem	Presumed cause and solution
<p>[- - - -] is flashing on the PV display.</p>	<ul style="list-style-type: none"> • The input signal wire for DC voltage (1 to 5 V DC) or current (4 to 20 mA DC) may be disconnected. Replace each input signal. How to check input signal wire disconnection [Voltage (1 to 5 V DC)] If the input to the input terminal of this controller is 1 V DC, and if scaling low limit value is indicated, the controller is likely to be operating normally, however, the signal wire may be disconnected. [Current (4 to 20 mA DC)] If the input to the input terminal of this controller is 4 mA DC, and if scaling low limit value is indicated, the controller is likely to be operating normally, however, the signal wire may be disconnected. • Check whether the input signal wire for voltage (1 to 5 V DC) or current (4 to 20 mA DC) is securely connected to the input terminal of this controller. Ensure that the input signal wire is connected to the controller input terminals securely. • Check whether the polarity of thermocouple or compensating lead wire is correct. Check whether codes (A, B, B) of RTD agree with the controller input terminals. Ensure that they are wired properly.
<p>The value set during the Scaling low limit setting remains on the PV display.</p>	<ul style="list-style-type: none"> • Check whether the input signal wire for voltage (0 to 5 V DC, 0 to 10 V DC) or current (0 to 20 mA DC) is disconnected. Replace each individual input signal wire. How to check input signal wire disconnection [Voltage (0 to 5 V DC, 0 to 10 V DC)] If the input to the input terminals of this controller is 1 V DC, and if a value (converted value from Scaling high, low limit setting) corresponding to 1 V DC is indicated, the controller is likely to be operating normally, however, the signal wire may be disconnected. [Current (0 to 20 mA DC)] If the input to the input terminals of this controller is 4 mA DC, and if a value (converted value from Scaling high, low limit setting) corresponding to 4 mA DC is indicated, the controller is likely to be operating normally, however, the signal wire may be disconnected. • Check whether the input terminals for voltage (0 to 5 V DC, 0 to 10 V DC) or current (0 to 20 mA DC) are securely connected to the controller input terminals. Ensure that the signal wire is securely connected to the controller input terminals.
<p>The indication of the PV display is irregular or unstable.</p>	<ul style="list-style-type: none"> • Check whether sensor input or temperature unit (°C or °F) setting is correct. Select the sensor input and the temperature unit properly. • Sensor correcting value is unsuitable. Set it to a suitable value. • Check whether the sensor specification is correct. Set the sensor specification properly. • AC may be leaking into the sensor circuit. Use an ungrounded type sensor. • There may be equipment that interferes with or makes noise near the controller. Keep equipment that interferes with or makes noise away from the controller.

Problem	Presumed cause and solution
[Err 1] is indicated on the PV display.	The internal memory is defective. Please contact our main office or dealers.

Key Operation

Problem	Presumed cause and solution
Settings (SV, P, I, D, proportional cycle, alarm value, etc.) are impossible. The value does not change by the Δ , ∇ keys.	<ul style="list-style-type: none"> • Set value lock (Lock 1 or Lock 2) is selected. Release the lock. • During AT or auto-reset. Cancel AT if required. Auto-reset will end 4 minutes after starting.
The setting indication does not change within the rated input range even if the Δ , ∇ keys are pressed, and new values are unable to be set.	<ul style="list-style-type: none"> • SV high limit or SV low limit may be set at the point where the value does not change. Set it again while in Auxiliary function setting mode 1.

Control

Problem	Presumed cause and solution
Temperature does not rise.	<ul style="list-style-type: none"> • The sensor is out of order. Replace the sensor. • Check whether sensor or control output terminals are securely connected to the input or output terminals of the instrument. • Ensure that the wiring of sensor and control output terminals are correct.
The control output remains in an ON status.	<ul style="list-style-type: none"> • OUT1 low limit value is set to 100% or higher in Auxiliary function setting mode 2. Set it to a suitable value.
The control output remains in an OFF status.	<ul style="list-style-type: none"> • OUT1 high limit value is set to 0% or less in Auxiliary function setting mode 2. Set it to a suitable value.

For all other malfunctions, please contact our main office or dealers.

11. Character Table

Photocopiable Material

[Main Setting Mode]

Character	Setting item	Default value	Data
S	SV1	0°C	

[Sub Setting Mode]

Character	Setting item	Default value	Data
AT	AT/Auto-reset	AT/Auto-reset Cancel	
P	OUT1 proportional band	10°C	
P_b	OUT2 proportional band	1.0 times	
I	Integral time	200 sec	
d	Derivative time	50 sec	
M	ARW	50%	

Character	Setting item	Default value	Data
<i>c</i> <input type="text"/>	OUT1 proportional cycle	30 sec or 3 sec	
<i>c</i> <input type="text"/> <i>_b</i> <input type="text"/>	OUT2 proportional cycle	30 sec or 3 sec	
<i>A</i> <input type="text"/> <i>1</i> <input type="text"/>	A1 value	0°C	
<i>A</i> <input type="text"/> <i>2</i> <input type="text"/>	A2 value	0°C	
<i>H</i> <input type="text"/> <input type="text"/>	Heater burnout alarm value	0.0 A	
<i>LP</i> <input type="text"/> <i>_T</i> <input type="text"/>	Loop break alarm time	0 minutes	
<i>LP</i> <input type="text"/> <i>_H</i> <input type="text"/>	Loop break alarm span	0°C	

[Auxiliary Function Setting Mode 1]

Character	Setting item	Default value	Data
<i>Lock</i>	Set value lock	Unlock	
<i>5H</i> <input type="text"/>	SV high limit	1370°C	
<i>5L</i> <input type="text"/>	SV low limit	-200°C	
<i>50</i> <input type="text"/>	Sensor correction	0.0°C	
<i>cn</i> <i>4L</i>	Communication protocol	Shinko protocol	
<i>cn</i> <i>no</i>	Instrument number	0	
<i>cn</i> <i>4P</i>	Communication speed	9600 bps	
<i>cn</i> <i>P</i> <i>r</i>	Parity	Even parity	
<i>cn</i> <i>4T</i>	Stop bit	1	

[Auxiliary Function Setting Mode 2]

Character	Setting item	Default value	Data
<i>5En</i> <i>4</i>	Input type	K: -200 to 1370°C	
<i>5TL</i> <i>H</i>	Scaling high limit	9999	
<i>5TL</i> <i>L</i>	Scaling low limit	-1999	
<i>dP</i> <input type="text"/>	Decimal point place	No decimal point	
<i>F</i> <i>L</i> <i>T</i>	PV filter time constant	0.0 seconds	
<i>oL</i> <i>H</i> <input type="text"/>	OUT1 high limit	100%	
<i>oL</i> <i>L</i> <input type="text"/>	OUT1 low limit	0%	
<i>H</i> <i>9</i> <i>4</i> <input type="text"/>	OUT1 ON/OFF hysteresis	1.0°C	
<i>c</i> <i>A</i> <i>c</i> <i>t</i>	OUT2 action mode	Air cooling	
<i>oL</i> <i>H</i> <i>b</i>	OUT2 high limit	100%	
<i>oL</i> <i>L</i> <i>b</i>	OUT2 low limit	0%	
<i>db</i> <input type="text"/>	Overlap/Dead band	0.0°C	
<i>H</i> <i>9</i> <i>4</i> <i>b</i>	OUT2 ON/OFF hysteresis	1.0°C	
<i>AL</i> <i>I</i> <i>F</i>	A1 type	No alarm action	
<i>AL</i> <i>2</i> <i>F</i>	A2 type	No alarm action	
<i>A</i> <i>1</i> <i>L</i> <i>n</i>	A1 action Energized/De-energized	Energized	
<i>A</i> <i>2</i> <i>L</i> <i>n</i>	A2 action Energized/De-energized	Energized	
<i>A</i> <i>1</i> <i>H</i> <i>9</i>	A1 hysteresis	1.0°C	
<i>A</i> <i>2</i> <i>H</i> <i>9</i>	A2 hysteresis	1.0°C	
<i>A</i> <i>1</i> <i>d</i> <i>9</i>	A1 action delay timer	0 seconds	
<i>A</i> <i>2</i> <i>d</i> <i>9</i>	A2 action delay timer	0 seconds	
<i>con</i> <i>t</i>	Direct (Cooling)/Reverse (Heating) action	Reverse (Heating) action	
<i>A</i> <i>T</i> <i>_</i> <i>b</i>	AT bias	20°C	
<i>5</i> <i>B</i> <i>_</i> <i>b</i>	SVTC bias	0	
<i>5</i> <i>ou</i> <i>T</i>	Output status when input abnormal	Outputs OFF(4 mA) or OUT1(OUT2) low limit.	
<i>n</i> <i>A</i> <i>n</i> <i>U</i>	OUT/OFF Key function	Control output OFF function	

***** Inquiries *****

For any inquiries about this unit, please contact our agency or the vendor where you purchased the unit after checking the following.

[Example]

- Model ----- JCM-33A-R/M
- Input type ----- K
- Option ----- A2, C5
- Serial number ----- No. xxxxxxxxx

In addition to the above, please let us know the details of the malfunction, or discrepancy, and the operating conditions.

SHINKO TECHNOS CO., LTD.
OVERSEAS DIVISION

Head Office: 2-5-1, Senbahigashi, Minoo, Osaka, 562-0035, Japan

[URL] <https://shinko-technos.co.jp/e/>

Tel: +81-72-727-6100

[E-mail] overseas@shinko-technos.co.jp

Fax: +81-72-727-7006