

INFRARED TEMPERATURE SENSOR

RD-600 SERIES

INSTRUCTION MANUAL



Shinko

Preface

Thank you for purchasing our Infrared Temperature Sensor RD-600 series. This manual contains instructions for the mounting, functions, operations and notes when operating the RD-600 series. To ensure safe and correct use, thoroughly read and understand this manual before using this instrument. To prevent accidents arising from the misuse of this instrument, please ensure the operator receives this manual.

Notes

- This instrument should be used in accordance with the specifications described in the manual. If it is not used according to the specifications, it may malfunction or cause a fire.
- Be sure to follow the warnings, cautions and notices. If they are not observed, serious injury or malfunction may occur.
- Specifications of the instrument and the contents of this instruction manual are subject to change without notice.
- Care has been taken to ensure that the contents of this instruction manual are correct, but if there are any doubts, mistakes or questions, please inform our sales department.
- This instrument is designed to be used in close proximity to the target object. Measures must be taken to ensure that the operator cannot touch power terminals or other high voltage sections.
- Any unauthorized transfer or copying of this document, in part or in whole, is prohibited.
- Shinko Technos Co., Ltd. is not liable for any damage or secondary damage(s) incurred as a result of using this product, including any indirect damage.

SAFETY PRECAUTIONS (Be sure to read these precautions before using our products.)

The safety precautions are classified into categories: "Warning" and "Caution".

Depending on the circumstances, procedures indicated by  Caution may cause serious results, so be sure to follow the directions for usage.



Warning

Procedures which may lead to dangerous conditions and cause death or serious injury, if not carried out properly.



Caution

Procedures which may lead to dangerous conditions and cause superficial to medium injury or physical damage or may degrade or damage the product, if not carried out properly.



Warning

- To prevent an electrical shock or fire, only Shinko or qualified service personnel may handle the inner assembly.
- To prevent an electrical shock, fire, or damage to instrument, parts replacement may only be undertaken by Shinko or qualified service personnel.



Safety Precautions

- To ensure safe and correct use, thoroughly read and understand this manual before using this instrument.
- This instrument is intended to be used for industrial machinery, machine tools and measuring equipment. Verify correct usage after purpose-of-use consultation with our agency or main office. (Never use this instrument for medical purposes with which human lives are involved.)
- External protection devices such as protective equipment against excessive temperature rise, etc. must be installed, as malfunction of this product could result in serious damage to the system or injury to personnel. Proper periodic maintenance is also required.
- This instrument must be used under the conditions and environment described in this manual. Shinko Technos Co., Ltd. does not accept liability for any injury, loss of life or damage occurring due to the instrument being used under conditions not otherwise stated in this manual.



Caution with Respect to Export Trade Control Ordinance

To avoid this instrument from being used as a component in, or as being utilized in the manufacture of weapons of mass destruction (i.e. military applications, military equipment, etc.), please investigate the end users and the final use of this instrument. In the case of resale, ensure that this instrument is not illegally exported.

1. Installation Precautions



Caution

- The sensing head should be kept as close as possible to the target object.
- When installing this sensor, no obstacles should be placed between the sensing head and target object.
- This sensor has a temperature operating range of -20 to 85 °C (for sensing head) and 0 to 65 °C (for electronics module).
- This sensor has a humidity operating range of 10 to 95 %RH (non-condensing).
- The sensing head lens should be protected from powder, dust, etc.
- Use an air purge collar (ATAL, sold separately) when this sensor is mounted in a place where fumes, dust, gases or contaminants are present.
(Airflow: 2 to 10 liters/minute)
- Install this sensor away from electrical noise, motors or generators.

2. Wiring Precautions



Warning

- Never connect the power supply to the analog output. The output circuit will break.

3. Measurement and Maintenance Precautions



Caution

- When using the air purge collar, make sure to use oil-free, clean compressed air.
- Clean the lens surface with a soft, damp cloth or tissue paper moistened with water or water based glass cleaner. (Never use cleaning compounds which contain solvents.)
- As the display section of the electronics module is vulnerable, do not strike or scratch it with a hard object or put pressure on it.
- The Average time is set to the minimum value as a factory default, so fluctuation may occur in indication and output action depending conditions.
In this case, set the Average time to a suitable value.

Contents

	Page
1. Model	
1.1 Model -----	5
1.2 How to Read the Model Label -----	5
2. Names and Functions of Sections -----	6
3. Target Objects -----	7
4. Installation	
4.1 Target Spot Size versus Distance from Sensing Head -----	8
4.2 Mounting	
4.2.1 Direct Mounting -----	9
4.2.2 Mounting when Mounting Bracket (TFB, sold separately) is Used -	10
4.2.3 Mounting when Air Purge Collar (ATAL, sold separately) is Used -	11
4.2.4 Mounting Using the Sighting Tube (Sold Separately) -----	13
4.2.5 Mounting the Electronics Module -----	14
5. Wiring	
5.1 Terminal Arrangement -----	15
5.1.1 Wiring of Power Supply -----	16
5.1.2 Analog Output -----	16
5.1.3 High Limit Alarm Output -----	17
5.2 Wiring Example -----	18
6. Setup -----	19
6.1 Turn the Power ON -----	20
6.2 Outline of Key Operation -----	20
6.3 Details of Setting Items -----	21
7. Measurement -----	26
8. Specifications -----	28
9. Troubleshooting -----	33
10. Key Operation Flowchart -----	34
11. Character Table -----	35
Appendix A: Emissivity Table: Metals -----	37
Appendix B: Emissivity Table: Non-Metals -----	39

1. Model

1.1 Model

Model	Spectral Range	Field of View	Temperature Range
RD-622-LM	2.3 μm	22:1	50 to 400 °C (*)
RD-675-HM	2.3 μm	75:1	150 to 1000 °C (*)

(*) Temperature of target object > Sensing head temperature + 25 °C

1.2 How to Read the Model Label

The serial number label is attached to the upper/front edge of the Electronics module.
The model label is attached to the lower/front edge (below the Shinko logo) of the Electronics module.

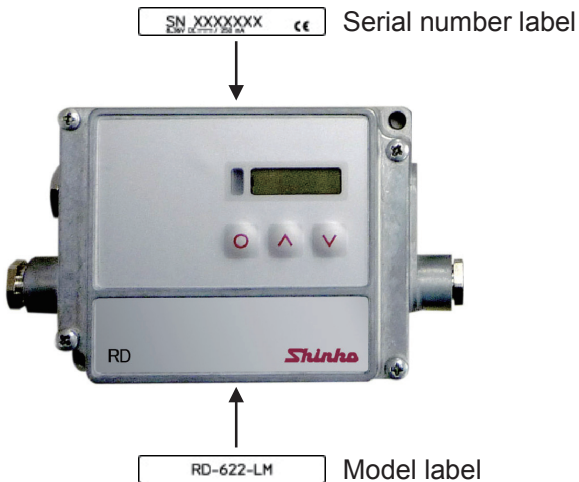

(Fig. 1.2-1)

2. Names and Functions of Sections



(Fig. 2-1)

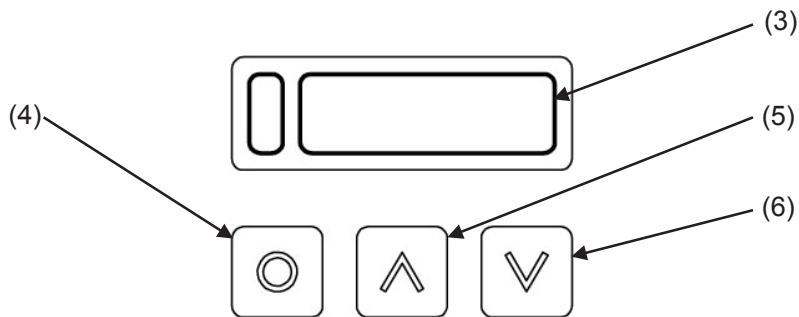

(Fig. 2-2)

(1) Electronics module

(2) Sensing head

(3) LCD display: Indicates a temperature. (If target object temperature is the same as or lower than, the temperature range low limit value, temperature range low limit value will be indicated.)

When normal, the backlight is green.

In the setting mode, setting items and set values are indicated.

When Low limit alarm output is ON, the backlight is blue.

When High limit alarm output is ON, the backlight is red.

When both Low limit alarm output and High limit alarm output are ON, the backlight is purple.

Indicates error messages in the event of sensing head temperature too low/too high, electronics module temperature too low/too high. (Backlight is green.)

(4) Mode Key: Selects a setting mode.

(5) Up Key: Increases the numeric value.

(6) Down Key: Decreases the numeric value.

3. Target Objects

Target objects are shown below.

- **Non-problematic objects**

Lustrous metal surfaces, secondary processed metals, metal oxide, ceramic materials

Measurement can be performed through general and heat-resistant glass.

Asphalt, papers, plastics, rubbers, textiles

- **Slightly problematic objects**

Low lustrous metals, thin transparent plastics, etc.

If measurement is difficult, black body tape can be used to raise emissivity.

4. Installation



Caution

- The sensing head should be kept as close as possible to the target object.
- When installing this sensor, no obstacles should be placed between the sensing head and target object.
- The target spot size should be the same or smaller than the target object.
Refer to Section 4.1 Target Spot Size versus Distance from Sensing Head.
- Indication may be unstable depending of the mounting environment. In this case, review the mounting environment. If indication is still unstable, it can be stabilized by setting the Average time. See [Average time] on p.22.
- The sensor has a temperature operating range of -20 to 85°C (for sensing head) and 0 to 65 °C (for electronics module).
- The sensor has a humidity operating range of 10 to 95%RH (non-condensing).
- The sensing head lens should be protected from powder, dust, etc.
- Use an air purge collar (ATAL, sold separately) when this sensor is mounted in a place where fumes, dust, gases or contaminants are present.
(Discharge air flow rate: 2 to 10 liters/minute)
- Install this sensor away from electrical noise, motors or generators.

* For installation of the mounting bracket (TFB, sold separately), refer to Section 4.2.2 Mounting Using the Mounting Bracket (TFB, sold separately) (p.10).
For installation of the air purge collar (ATAL, sold separately), refer to Section 4.2.3 Mounting when Air Purge Collar (ATAL (sold separately) is Used (pages 11-13).

4.1 Target Spot Size versus Distance from Sensing Head

(Fig. 4.1-1, Fig. 4.1-2) show the relationship between the target spot size and distance from the sensing head. Not to scale.

Take these values into consideration when installing the sensor.

Field of view D:S = 22:1 (Model: RD-622-LM)

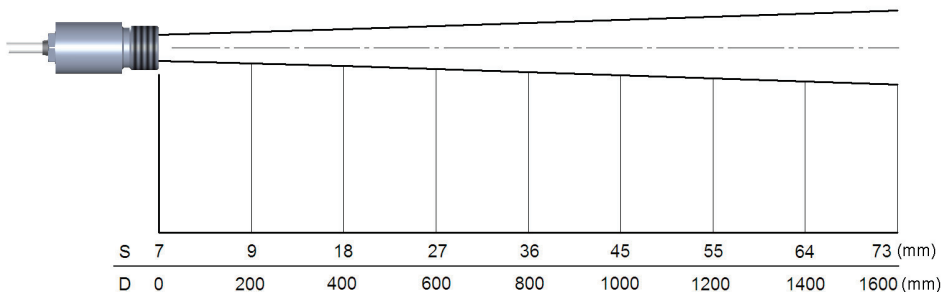

S: Target spot size

D: Distance from the front of the sensing head to the object

(Fig. 4.1-1)

Field of view D:S = 75:1 (Model: RD-675-HM)

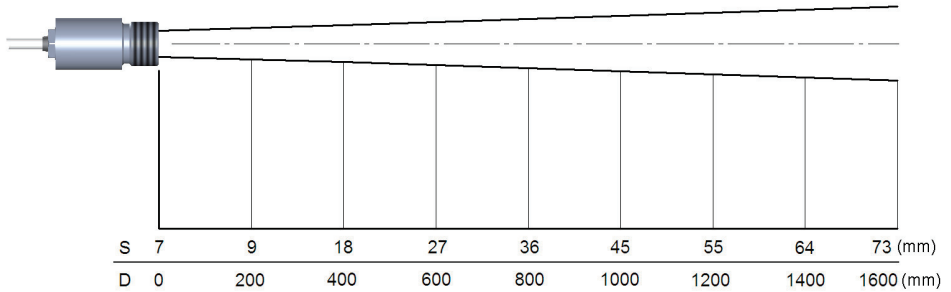

S: Target spot size

D: Distance from the front of the sensing head to the object

(Fig. 4.1-2)

4.2 Mounting

There are 3 methods for mounting the sensing head.

- Direct mounting
- Mounting when mounting bracket (TFB, sold separately) is used
- Mounting when air purge collar (ATAL, sold separately) is used

4.2.1 Direct Mounting

The sensing head is threaded (M12 x 1) for mounting directly into an appropriately sized hole.

Remember to remove the nut before mounting.

Sensing head dimensions (Scale: mm)

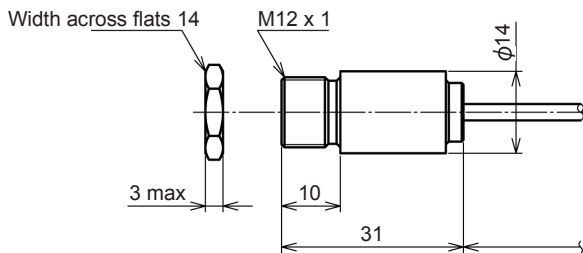

(Fig. 4.2.1-1)

4.2.2 Mounting when Mounting Bracket (TFB, sold separately) is Used

When using the mounting bracket, the sensing head can be easily mounted anywhere.

Mounting bracket (TFB) dimensions (Scale: mm)

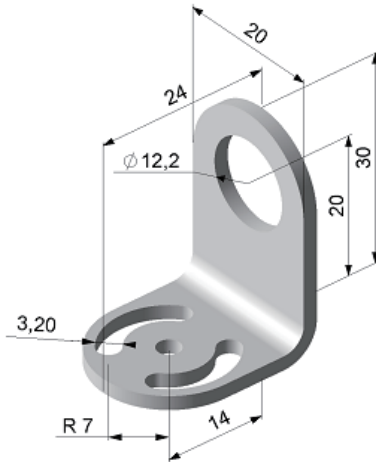

(Fig. 4.2.2-1)

Mounting procedures are shown below.

- (1) Fix the mounting bracket at the desired site using a screw (M3 size – not included).
- (2) Remove the included hexagonal nut from the sensing head, and pass the sensing head through the mounting bracket. Secure it using the hexagonal nut.



(Fig. 4.2.2-2)

4.2.3 Mounting when Air Purge Collar (ATAL, sold separately) is Used

The air purge collar is used to suppress rises in temperature of the sensing head, and to keep fumes, dust, gases and other contaminants away from the lens. The mounting bracket (TFB, sold separately) is also necessary.

- Airflow: 2 to 10 liters/minute
- Use clean, oil-free compressed air.

Air purge collar (ATAL) dimensions (Scale: mm)

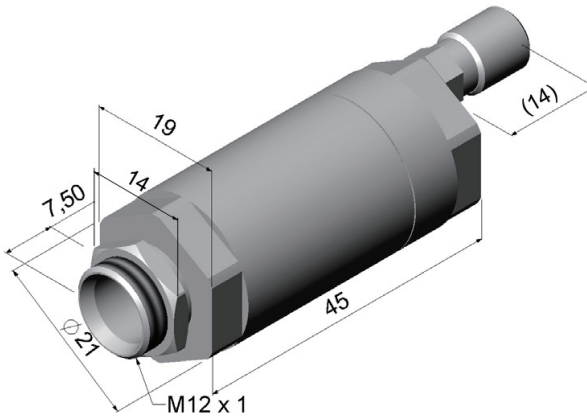

(Fig. 4.2.3-1)

Mounting procedures are shown below.

- (1) Remove cover of the Electronics module, and disconnect the sensing head cables from the terminals in the module.

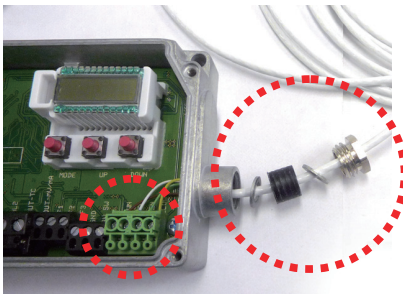
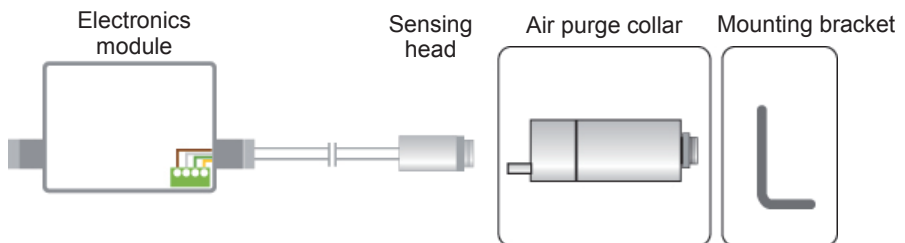

(Fig. 4.2.3-2)

(2) Unscrew the back part of the air purge collar from the front part.



(Fig. 4.2.3-3)

(3) Screw the sensing head into the front part of the air purge collar.

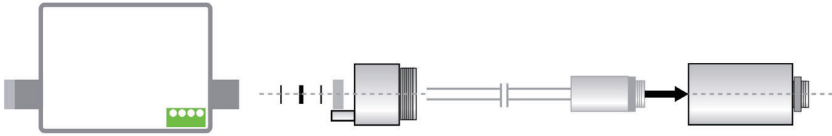

(Fig. 4.2.3-4)

(4) Pass the sensing head cables through the back part of the air purge collar.

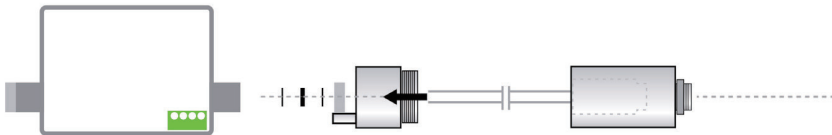

(Fig. 4.2.3-5)

(5) Screw the back part of the air purge collar onto the front part.



(Fig. 4.2.3-6)

(6) Reconnect the sensing head cables in the module.

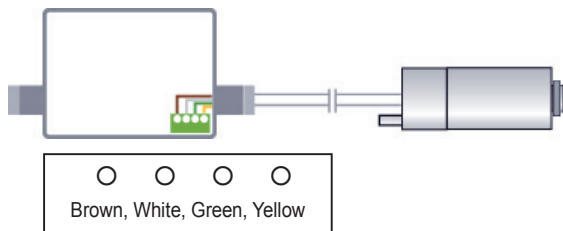

(Fig. 4.2.3-7)

(7) Fix the mounting bracket (TFB, sold separately) at the desired site using a screw. (M3 size – not included)

- (8) Pass the air purge collar through the mounting bracket, and fix the collar using the hexagonal nut provided.

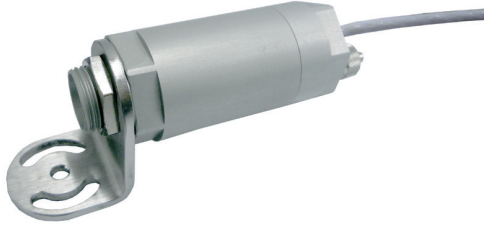

(Fig. 4.2.3-8)

- (9) Attach the tube and air pump to the air purge collar.

Refer to the tube size and air pump specifications recommended below.

Recommended tube size: Inside diameter: 4 mm; Outside diameter: 6 mm

Recommended air pump: Air pump should fit tube size and deliver a discharge air flow rate corresponding to the air purge collar (2 to 10 liters/minute).

4.2.4 Mounting Using the Sighting Tube (Sold Separately)

By mounting the Sighting tube, unwanted background infrared near the target object can be blocked.

[Sighting tube 40 mm (AST40APA, for RD-622-LM),

Sighting tube 88 mm (AST88APA, for RD-675-HM)]

Sighting tube adapter is included with the Sighting tube.

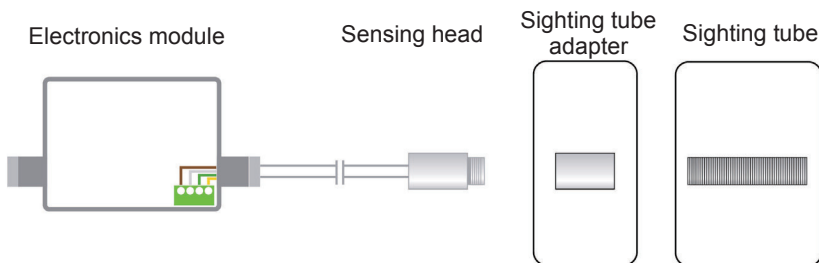

(Fig. 4.2.4-1)

The following outlines the procedure for installation.

- (1) Screw the Sighting tube adapter securely to the sensing head.



(Fig. 4.2.4-2)

(2) Screw the Sighting tube into the attached Sighting tube adapter.



(Fig. 4.2.4-3)



(Fig. 4.2.4-4)

For mounting to the Mounting bracket (TFB), see Section [4.2.2 Mounting when Mounting Bracket (TFB, sold separately) is Used] (p.10).

4.2.5 Mounting the Electronics Module

Fix the module at the desired site with screws (M4 size – not included).

Electronics module dimensions (Scale: mm)

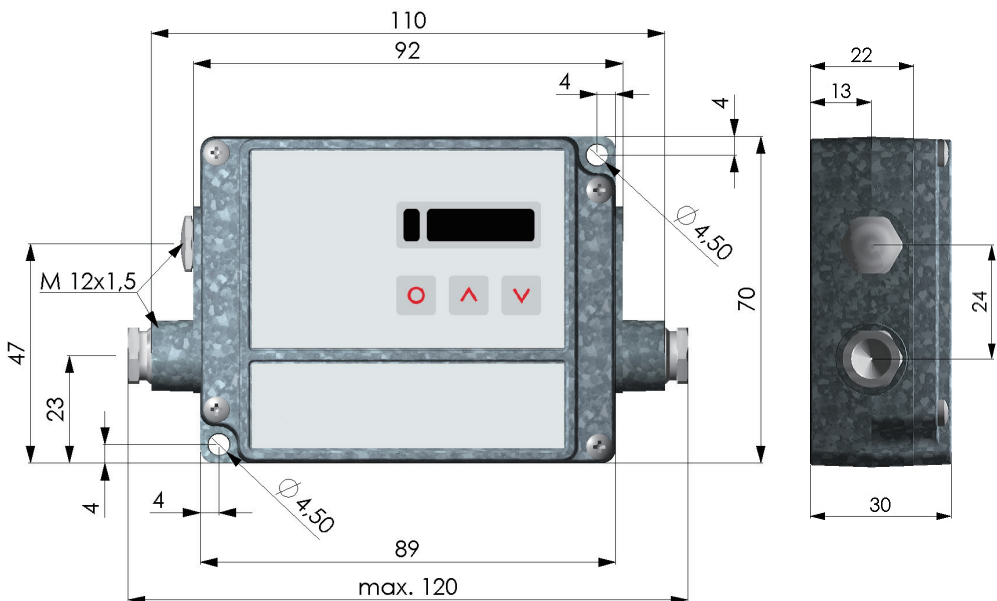

(Fig. 4.2.5-1)

5. Wiring



Warning

- Turn the power supply to any connected instruments (indicators, controllers, etc.) OFF before wiring.
- Working on or touching the terminal with the power switched ON may result in severe injury or death due to electric shock.
- Never connect the power supply to the analog output. Output circuit will break.



Caution

When using this sensor in a place where electrical noise is present, connect the shield (using a shielded wire) to the ground terminal of any connected instruments (indicators, controllers, etc.).
If they have no ground terminal, connect the shield to the ground terminal of the control panel.

5.1 Terminal Arrangement

With the cover removed from the electronics module, terminals are attached as follows.

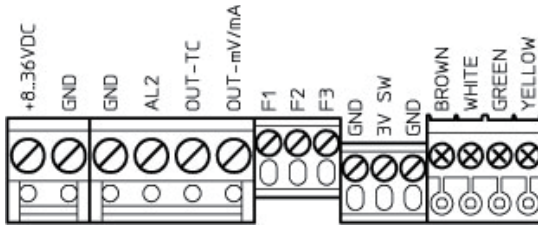

(Fig. 5.1-1)

Terminal Name	Contents
+8..36 VDC	Power supply
GND	GND (Power supply)
GND	GND (Internal input/output)
AL2	High limit alarm output (Open collector output)
OUT-TC	Analog output (Thermocouple K, J)
OUT-mV/mA	Analog output (DC voltage, current)
F1-F3	Not used
GND	Not used
3V-SW	Not used
GND	Not used
BROWN	Sensing head temperature signal (*)
WHITE	Sensor GND (*)
GREEN	Sensor power supply (*)
YELLOW	Target temperature signal (*)

(*) Connected prior to being shipped.

5.1.1 Wiring of Power Supply

Use 8 to 36 V DC power supply (Max. 100 mA).

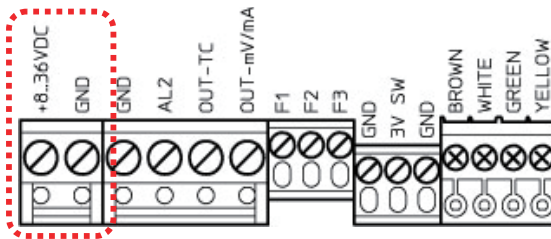

(Fig. 5.1.1-1)

5.1.2 Analog Output

Analog output terminals differ depending on the output selected in [Analog output (p.21)].

Analog Output		Terminals
DC voltage	0 to 5 V DC	OUT-mV/mA, GND
Direct current	0 to 20 mA DC	OUT-mV/mA, GND
Direct current	4 to 20 mA DC	OUT-mV/mA, GND
Thermocouple	K	OUT-TC, GND
Thermocouple	J	OUT-TC, GND
DC voltage	0 to 10 V DC	OUT-mV/mA, GND

- DC voltage: 0 to 5 V DC, 0 to 10 V DC
 Load resistance: 100 k Ω or more
- Direct current: 0 to 20 mA DC, 4 to 20 mA DC
 Load resistance: 500 Ω or less
- Thermocouple: K, J
 Output impedance 20 Ω

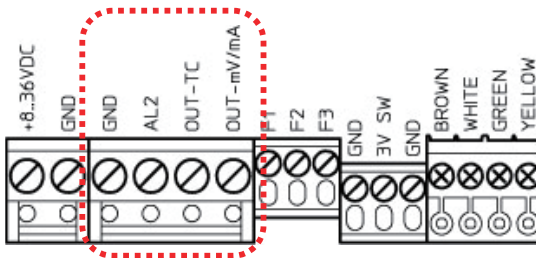

(Fig. 5.1.2-1)

5.1.3 High Limit Alarm Output

High limit alarm output: Open collector type

Capacity: 24 V DC, Max. 50 mA

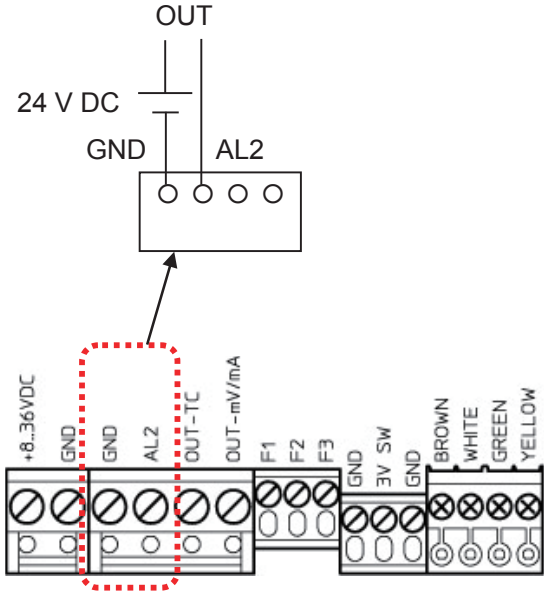

(Fig. 5.1.3-1)

5.2 Wiring Example

Wiring example between RD-600 series (analog output 0 to 10 V DC) and Shinko digital indicator JIR-301-M (0 to 10 V DC input) is shown below.

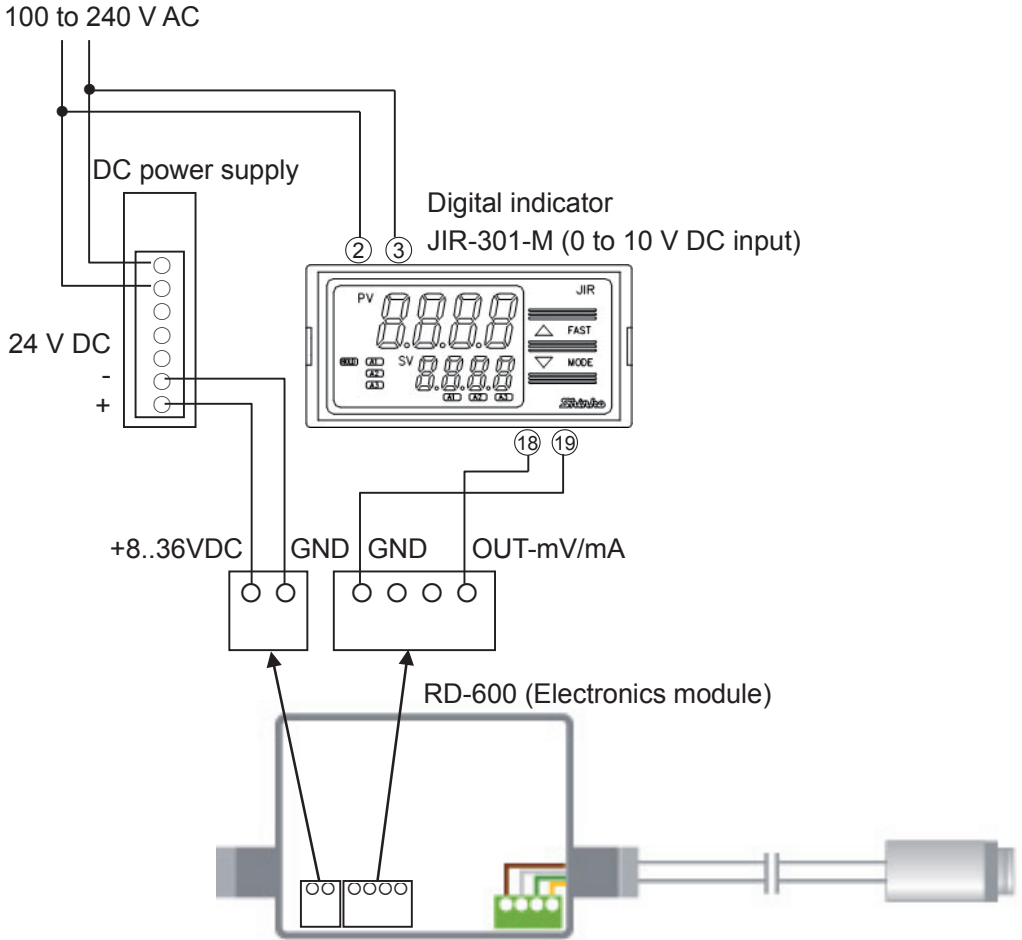

(Fig. 5.2-1)

6. Setup

Setup should be done before using this instrument, in order to select Analog output, Emissivity, Analog output scaling low limit, Analog output scaling high limit, Analog output low limit, Analog output high limit, Alarm, etc. according to the users' conditions.

Factory defaults are shown in (Table 6-1).

(Table 6-1)

Setting Item	Factory Default
Analog output	0 to 5 V DC
Emissivity	1.000
Transmissivity	1.000
Average time	0.001 seconds
Peak hold time	OFF
Valley hold time	OFF
Analog output scaling low limit	Temperature range low limit
Analog output scaling high limit	Temperature range high limit
Analog output low limit	0.00 V DC
Analog output high limit	5.00 V DC
Temperature unit	°C
Low limit alarm value	(Table 6-2)
High limit alarm value	
Ambient temperature compensation (sensor)	Sensing head temperature

(Table 6-2)

Model	Factory Default	
	Low Limit Alarm Value	High Limit Alarm Value
RD-622-LM	100.0 °C	300.0 °C
RD-675-HM	350.0 °C	600.0 °C

If the users' specification is the same as the factory default of the sensor, or if setup has already been completed, it is not necessary to set up the instrument. Proceed to Section 7. Measurement (p.26).

6.1 Turn the Power ON

After the power is turned ON, the LCD display indicates `.I.N.I.T` for several seconds.

After that, the temperature of the target object will be indicated on the LCD display. Backlight of the LCD display differs depending on the RD-600 status.

RD-600 Status	Backlight
When normal	Green
When Low limit alarm output is ON.	Blue
When High limit alarm output is ON	Red
When both Low limit alarm and High limit alarm are ON.	Purple

6.2 Outline of Key Operation

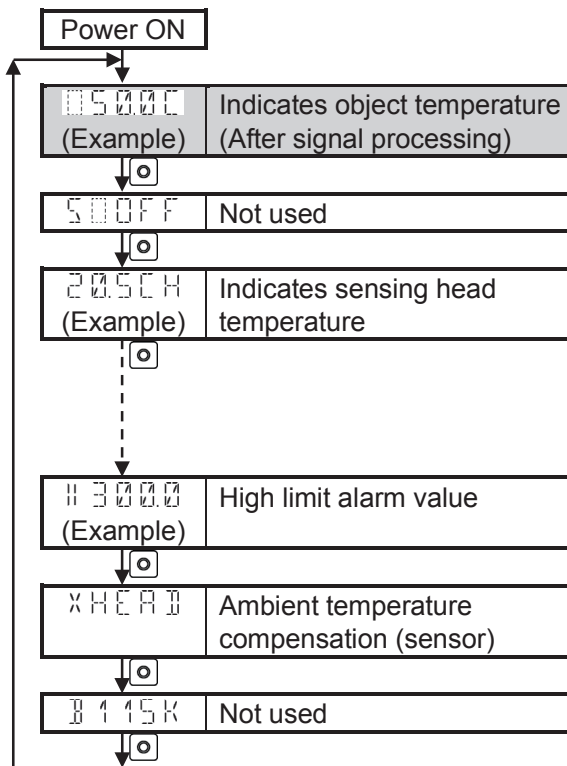

About Key Operation



- By pressing the key, the instrument proceeds to each setting item.
- Set each setting item with the or key. Set values are immediately validated.
- If 10 seconds elapse with no selection made, the instrument automatically returns to `0500C` [Indicates object temperature (After signal processing)].
- If the key is pressed again, the instrument will revert to the last setting item.

6.3 Details of Setting Items

Display	Name, Function, Setting Range	Factory Default
0500C (Example)	Indicates object temperature (After signal processing) • Indicates temperature of the target object after signal is processed if functions such as average time, peak hold and valley hold are set.	
500FF	Not used • Do not set this item as this setting item is not used.	
205CH (Example)	Indicates sensing head temperature • Indicates the sensing head temperature.	
025CB (Example)	Indicates electronics module inner temperature • Indicates interior temperature of the electronics module.	
050CA (Example)	Indicates current target temperature • Indicates current temperature of the target object.	
00MV5	Analog output • Selects an analog output signal. • 00MV5: 0 to 5 V DC • 00-20: 0 to 20 mA DC • 04-20: 4 to 20 mA DC • 0TEK: Thermocouple K • 0TEJ: Thermocouple J • 0MV10: 0 to 10 V DC	0 to 5 V DC
E 1000	Emissivity • Sets emissivity. For the emissivity setting, refer to [Emissivity (p.25)] and Appendix A (Emissivity Table: Metals) and Appendix B (Emissivity Table: Non-Metals) (pages 37 to 39). • Setting range: 0.100 to 1.100	1.000

Display	Name, Function, Setting Range	Factory Default
T 1.0000	Transmissivity <ul style="list-style-type: none"> Sets transmissivity. Set this value when optical components (protective window, lens, etc.) are mounted between sensor and target object. If no optical components are mounted, set the value to 1.000 (100%). Setting range: 0.100 to 1.100 	1.000
A 0.001	Average time <ul style="list-style-type: none"> Sets average time (time constant). Indication or output action will be averaged by setting the average time (time constant). A - - - -: OFF 0.001 to 999.9 seconds 	0.001 seconds
P - - - -	Peak hold time <ul style="list-style-type: none"> Sets peak hold time. Sets length of time to hold the peak value while the temperature descends. After hold time has passed, the signal will drop down to the second highest value (this is indicated as a peak value), or will descend by 1/8 of the difference between the previous peak and the minimum value during hold time. This value will be held for the specified length of time. Peak hold and valley hold cannot be set simultaneously. Refer to [Peak Hold (p.25)]. P - - - -: OFF 0.001 to 999.8 seconds P 0000: ∞ 	OFF
V - - - -	Valley hold time <ul style="list-style-type: none"> Sets valley hold time. Sets length of time to hold the valley value while the temperature ascends. After hold time has passed, the signal will ascend to the second lowest value (this is indicated as a valley value), or will ascend by 1/8 of the difference between the previous valley value and the maximum value during hold time. This value will be held for the specified length of time. Valley hold and peak hold cannot be set simultaneously. V - - - -: OFF 0.001 to 999.8 seconds V 0000: ∞ 	OFF

Display	Name, Function, Setting Range	Factory Default										
u 050.0 or u 150.0	Analog output scaling low limit <ul style="list-style-type: none"> • Sets Analog output scaling low limit value. Minimum scaling span is 20.0 °C. If Analog output scaling low limit value is set to a value higher than Analog output scaling high limit value, Analog output scaling high limit value will be automatically set to [Analog output scaling low limit + 20.0 °C]. • Not available if <input type="radio"/> T C K (thermocouple K) or <input type="radio"/> T C J (thermocouple J) is selected in [Analog output]. • Setting range: Temperature range low limit to [Analog output scaling high limit – 20.0 °C] 	(Table 6.3-2, p.24)										
n 400.0 or n 100.0	Analog output scaling high limit <ul style="list-style-type: none"> • Sets Analog output scaling high limit value. Minimum scaling span is 20.0 °C. Analog output scaling high limit value cannot be set to a value lower than [Analog output scaling low limit + 20.0 °C]. • Not available if <input type="radio"/> T C K (thermocouple K) or <input type="radio"/> T C J (thermocouple J) is selected in [Analog output]. • Setting range: [Analog output scaling low limit + 20.0 °C] to Temperature range high limit 	(Table 6.3-2, p.24)										
c 00.00	Analog output low limit <ul style="list-style-type: none"> • Sets the Analog output low limit value. • Analog output low limit value corresponds to the Analog output scaling low limit value. • Not available if <input type="radio"/> T C K (thermocouple K) or <input type="radio"/> T C J (thermocouple J) is selected in [Analog output]. • Setting range differs depending on the selection in [Analog output]. <p>(Table 6.3-1)</p> <table border="1"> <thead> <tr> <th>Analog Output</th> <th>Setting Range</th> </tr> </thead> <tbody> <tr> <td>0 to 5 V DC</td> <td>0.00 to 5.00 V DC</td> </tr> <tr> <td>0 to 20 mA DC</td> <td>0.00 to 20.00 mA DC</td> </tr> <tr> <td>4 to 20 mA DC</td> <td>4.00 to 20.00 mA DC</td> </tr> <tr> <td>0 to 10 V DC</td> <td>0.00 to 10.00 V DC</td> </tr> </tbody> </table>	Analog Output	Setting Range	0 to 5 V DC	0.00 to 5.00 V DC	0 to 20 mA DC	0.00 to 20.00 mA DC	4 to 20 mA DC	4.00 to 20.00 mA DC	0 to 10 V DC	0.00 to 10.00 V DC	0.00 V DC
Analog Output	Setting Range											
0 to 5 V DC	0.00 to 5.00 V DC											
0 to 20 mA DC	0.00 to 20.00 mA DC											
4 to 20 mA DC	4.00 to 20.00 mA DC											
0 to 10 V DC	0.00 to 10.00 V DC											
j 05.00	Analog output high limit <ul style="list-style-type: none"> • Sets the Analog output high limit value. • Analog output high limit value corresponds to the Analog output scaling high limit value. • Not available if <input type="radio"/> T C K (thermocouple K) or <input type="radio"/> T C J (thermocouple J) is selected in [Analog output]. • Setting range differs depending on the selection in [Analog output]. <p>Setting range: The same as (Table 6.3-1) above.</p>	5.00 V DC										

Display	Name, Function, Setting Range	Factory Default
U00°C	Temperature unit • Selects the temperature unit. • U00°C: °C U00°F: °F	°C
I 100.0 or I 350.0	Low limit alarm value • Sets Low limit alarm value. Hysteresis is fixed to 2 °C. • Setting range: -50.0 to 400.0 °C (RD-622-LM) 150.0 to 1000 °C (RD-675-HM)	(Table 6.3-3)
H 300.0 or H 600.0	High limit alarm value • Sets High limit alarm value. Hysteresis is fixed to 2 °C. • Setting range: -50.0 to 400.0 °C (RD-622-LM) 150.0 to 1000 °C (RD-675-HM)	(Table 6.3-3)
XHEAD	Ambient temperature compensation (sensor) • Sets ambient temperature. When emissivity of the target object is low, the sensing head will read reflected energy from the nearby background. This effect can be compensated by setting the ambient temperature of the object. If the ambient temperature of the object and sensing head temperature are the same, select XHEAD. If the ambient temperature of the object and sensing head temperature are different, set the ambient temperature of the target object. • XHEAD: Sensing head temperature (automatically compensates using the sensor inner temperature.) Setting range: RD-622-LM: -50.0 to 605.0 °C (-58.0 to 1121 °F) RD-675-HM: -50.0 to 1010 °C (-58.0 to 1850 °F) If the  and  keys are pressed simultaneously, the sensor reverts to XHEAD (Sensing head temperature).	Sensing head temperature
B 115K	Not used Do not set this item as this setting item is not used.	

(Table 6.3-2)

Model	Factory Default	
	Analog output scaling low limit	Analog output scaling high limit
RD-622-LM	50.0 °C	400.0 °C
RD-675-HM	150.0 °C	1000 °C

(Table 6.3-3)

Model	Factory Default	
	Low limit alarm value	High limit alarm value
RD-622-LM	100.0 °C	300.0 °C
RD-675-HM	350.0 °C	600.0 °C

Emissivity

Emissivity is a ratio between the amount of energy radiated from a black body with a certain temperature (or an object with perfect radiation), and the amount of energy radiated from an object with the same temperature.

Accordingly, emissivity value is high for an object which easily radiates infrared, and low for an object which radiates infrared with some difficulty.

For objects such as organic substances and ceramics, etc. (except metals), their emissivity value is high, which ensures a highly accurate measurement.

On the other hand, emissivity is low in lustrous metals and lustrous objects, resulting in measurement being affected by reflection. By attaching a black body tape to the object surface, high measurement accuracy can be obtained.

For tables of emissivity, refer to Appendix A (Emissivity Table: Metals) and Appendix B (Emissivity Table: Non-Metals) at the end of this manual. (Pages 37 to 39)

Peak Hold:

The following diagram shows the result of the peak hold process, set at 1 sec.

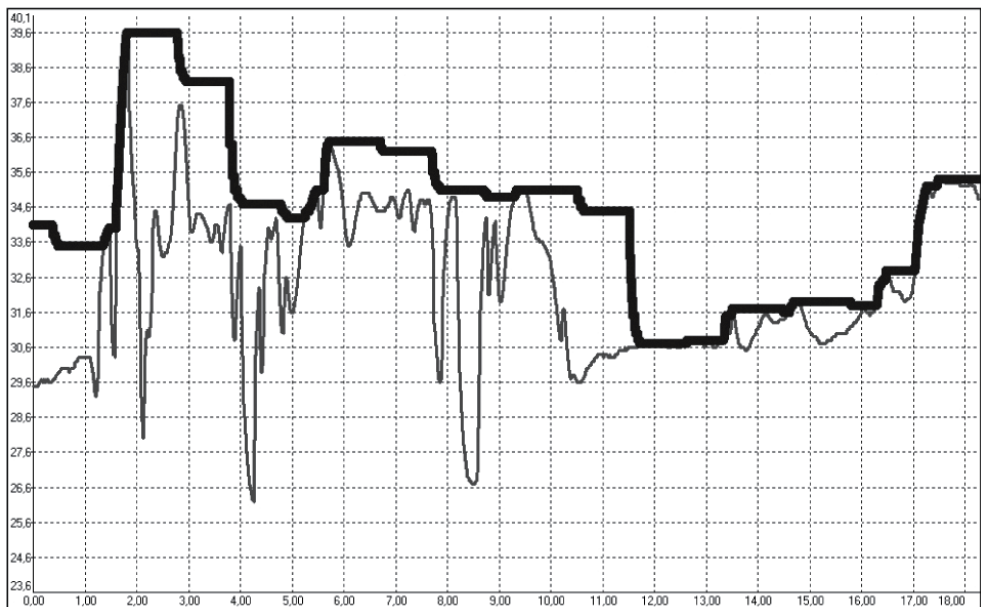

■ : Peak value has been held. (Peak hold time: 1 sec)

— : Original measurement values

(Fig. 6.3-1)

7. Measurement

Important

- If ambient temperature is rapidly changing, leave the sensor for more than 20 minutes as it is, then measure the temperature.
- Do not measure temperature near a large magnetic field (example: Arc welding machine, induction heater, etc.). Measurement errors will occur due to electromagnetic disturbance.
- Indication may not be stable due to the mounting environment.
The sensor will detect any light reflected from the target object from surrounding light sources.

After installation of the target object and wiring are completed, start operation, following the procedures below.

(1) Turn the power ON.

After the power is turned ON, the LCD display indicates `..I.N.I.T` for several seconds. After that, the temperature of the target object will be indicated on the LCD display.

Backlight Color Switching

Backlight of the LCD display differs depending on the RD-600 status.

RD-600 Status	Backlight
When normal	Green
When Low limit alarm output is ON.	Blue
When High limit alarm output is ON	Red (Open collector output ON)
When both Low limit alarm output and High limit alarm output are ON.	Purple (High limit alarm output: Open collector output ON)

Error message

When errors occur, an error message will appear. (Backlight: Green)

For the error contents, see (Table 7-1, p.27).

(e.g.)

LCD Display	Contents
ERR24	2: Electronics module low temperature 4: Sensing head low temperature

(2) Turn the indicator/controller power ON. (When indicator/controller is connected)

(3) Start the temperature measurement.

(Table 7-1)

ERR □ □		Contents
	0	Normal
	1	Short-circuit between Sensing head temperature signal (Terminal name: BROWN) and GND (Terminal name: GND)
	2	Electronics module low temperature
	4	Electronics module high temperature
	6	Electronics module probe burnout
	8	Short-circuit between Electronics module probe and GND (Terminal name: GND)
	0	Normal
	2	Target object high temperature
	4	Sensing head low temperature
	8	Sensing head high temperature
	C	Sensing head temperature signal (Terminal name: BROWN) burnout

8. Specifications

Rating

Temperature Range	<table border="1"> <thead> <tr> <th>Model</th> <th>Temperature Range</th> </tr> </thead> <tbody> <tr> <td>RD-622-LM</td> <td>50 to 400 °C (*)</td> </tr> <tr> <td>RD-675-HM</td> <td>150 to 1000 °C (*)</td> </tr> </tbody> </table>		Model	Temperature Range	RD-622-LM	50 to 400 °C (*)	RD-675-HM	150 to 1000 °C (*)
	Model	Temperature Range						
	RD-622-LM	50 to 400 °C (*)						
RD-675-HM	150 to 1000 °C (*)							
(*) Temperature of target object > Sensing head temperature+25°C								
Supply Voltage	8 to 36 V DC, Max. 100 mA							

General Structure

External Dimensions	Sensing head: 31 x ϕ 14 mm, M12 x 1 Electronics module: 89 x 70 x 30 mm (W x H x D)			
Mounting	Sensing head: Mounting bracket (sold separately) Electronics module: Mounting by screws			
Material	Sensing head: Stainless steel Electronics module: Die-cast zinc			
Drip-proof/Dust-proof	IP65			
Cable Length	3 m			
Cable Diameter	ϕ 2.8 mm			
Safety Standards	CE mark certified			
Display	<table border="1"> <tr> <td>LCD display</td> <td> 5 digits Backlight: When normal: Green When Low limit alarm output is ON: Blue When High limit alarm output is ON: Red When both Low limit alarm output and High limit alarm output are ON: Purple </td> </tr> </table>		LCD display	5 digits Backlight: When normal: Green When Low limit alarm output is ON: Blue When High limit alarm output is ON: Red When both Low limit alarm output and High limit alarm output are ON: Purple
LCD display	5 digits Backlight: When normal: Green When Low limit alarm output is ON: Blue When High limit alarm output is ON: Red When both Low limit alarm output and High limit alarm output are ON: Purple			

Performance

System Accuracy (*1)	Direct current output, DC voltage output: $\pm(0.3\% \text{ of reading} + 2\text{ }^\circ\text{C})$ (*2) Thermocouple output: $\pm 2.5\text{ }^\circ\text{C}$ or $\pm 1\% \text{ of reading}$, whichever is greater However, 50 to 150 $^\circ\text{C}$: Accuracy is not guaranteed.						
Spectral Range	2.3 μm						
Field-of-view	<table border="1"> <thead> <tr> <th>Model</th> <th>Field-of-view</th> </tr> </thead> <tbody> <tr> <td>RD-622-LM</td> <td>22:1</td> </tr> <tr> <td>RD-675-HM</td> <td>75:1</td> </tr> </tbody> </table>	Model	Field-of-view	RD-622-LM	22:1	RD-675-HM	75:1
Model	Field-of-view						
RD-622-LM	22:1						
RD-675-HM	75:1						
Repeatability (*1)	$\pm(0.1\% \text{ of reading} + 1\text{ }^\circ\text{C})$ (*2)						
Temperature Coefficient(*3)	$\pm 0.05\text{ }^\circ\text{C}/^\circ\text{C}$ or $\pm 0.05\% / ^\circ\text{C}$, whichever is greater						
Temperature Resolution	0.1 $^\circ\text{C}$ (*2)						
Response Time	1 ms (90 % response) (*4)						
Emissivity	0.100 to 1.100						
Transmissivity	0.100 to 1.100						
Signal Processing	Average, Peak hold, Valley hold						

(*1) Ambient temperature: $23 \pm 5\text{ }^\circ\text{C}$

(*2) $\mathcal{E}=1/\text{Response time 1 sec}$

(*3) When ambient temperature (sensing head) is lower than $18\text{ }^\circ\text{C}$ and higher than $28\text{ }^\circ\text{C}$

(*4) Dynamic adaptation at low signal levels

Output

Analog Output	Selectable from 0 to 20 mA DC, 4 to 20 mA DC, 0 to 5 V DC, 0 to 10 V DC, thermocouple K, J	
	Direct current	0 to 20 mA DC, 4 to 20 mA DC Load resistance: 500 Ω or less
	DC voltage	0 to 5 V DC, 0 to 10 V DC Load resistance: 100 k Ω or more
	Thermocouple	K, J Output impedance: 20 Ω
Alarm Output	High limit alarm Open collector output Capacity: 24 V DC, Max. 50 mA	

Attached Functions

<p>Warm-up Indication</p>	<p>After the power is turned ON, the LCD display indicates <code>.I.N.I.T</code> for several seconds. After that, the temperature of the target object will be indicated on the LCD display. Backlight of the LCD display differs depending on the alarm status.</p>										
<p>Backlight Color Switching</p>	<p>If alarm is turned ON, backlight of the LCD display differs depending on the RD-600 status.</p> <table border="1" data-bbox="552 468 1220 864"> <thead> <tr> <th data-bbox="552 468 848 510">RD-600 Status</th> <th data-bbox="848 468 1220 510">Backlight</th> </tr> </thead> <tbody> <tr> <td data-bbox="552 510 848 550">When normal</td> <td data-bbox="848 510 1220 550">Green</td> </tr> <tr> <td data-bbox="552 550 848 630">When Low limit alarm output is ON.</td> <td data-bbox="848 550 1220 630">Blue</td> </tr> <tr> <td data-bbox="552 630 848 710">When High limit alarm output is ON.</td> <td data-bbox="848 630 1220 710">Red (Open collector output ON)</td> </tr> <tr> <td data-bbox="552 710 848 864">When both Low limit alarm output and High limit alarm output are ON</td> <td data-bbox="848 710 1220 864">Purple (High limit alarm output: Open collector output ON)</td> </tr> </tbody> </table>	RD-600 Status	Backlight	When normal	Green	When Low limit alarm output is ON.	Blue	When High limit alarm output is ON.	Red (Open collector output ON)	When both Low limit alarm output and High limit alarm output are ON	Purple (High limit alarm output: Open collector output ON)
RD-600 Status	Backlight										
When normal	Green										
When Low limit alarm output is ON.	Blue										
When High limit alarm output is ON.	Red (Open collector output ON)										
When both Low limit alarm output and High limit alarm output are ON	Purple (High limit alarm output: Open collector output ON)										
<p>Error Message</p>	<p>When errors occur, an error message will appear. (Backlight: Green) For the error messages, see (Table 7-1, p.27). (e.g.)</p> <table border="1" data-bbox="552 1098 1220 1258"> <thead> <tr> <th data-bbox="552 1098 756 1140">LCD Display</th> <th data-bbox="756 1098 1220 1140">Contents</th> </tr> </thead> <tbody> <tr> <td data-bbox="552 1140 756 1258"><code>ERR24</code></td> <td data-bbox="756 1140 1220 1258"> 2: Electronics module low temperature 4: Sensing head low temperature </td> </tr> </tbody> </table>	LCD Display	Contents	<code>ERR24</code>	2: Electronics module low temperature 4: Sensing head low temperature						
LCD Display	Contents										
<code>ERR24</code>	2: Electronics module low temperature 4: Sensing head low temperature										

Other

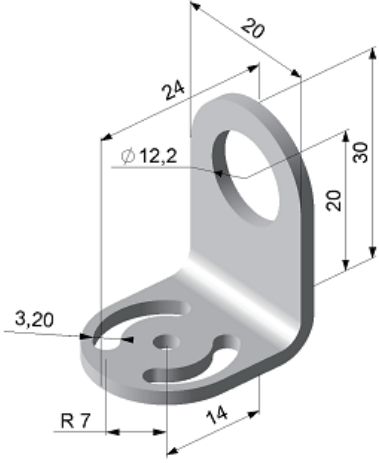
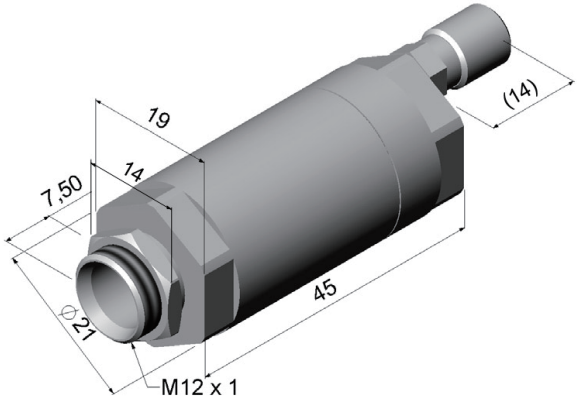
Ambient Temperature	Sensing head: -20 to 85 °C Electronics module: 0 to 65 °C
Storage Temperature	Sensing head: -40 to 85 °C Electronics module: -40 to 85 °C
Ambient Humidity	10 to 95 %RH (non-condensing)
Vibration (sensing head)	IEC 68-2-6: 3 G, 11-200 Hz, x,y,z directional
Shock (sensing head)	IEC 68-2-27: 50 G, 11 ms, x,y,z directional
Weight	Sensing head: 40 g Electronics module: 420 g
Accessories Included	Instruction manual: 1 copy, Nut: 1 piece
Accessories Sold Separately	<p>Mounting bracket (TFB)</p>  <p>Air purge collar (ATAL)</p> 

Power supply for the RD series (RDP-24)



Sighting tube – 40 mm (AST40APA, for RD-622-LM)

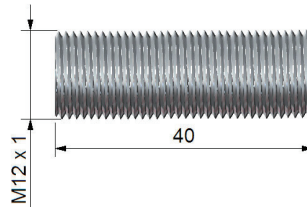

Sighting tube – 88 mm (AST88APA, for RD-675-HM)

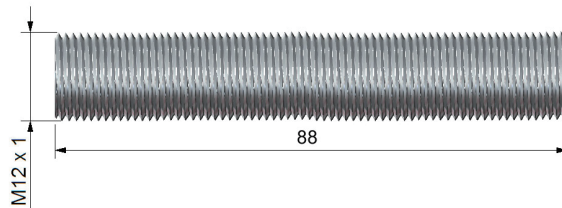

Sighting tube adapter (included)

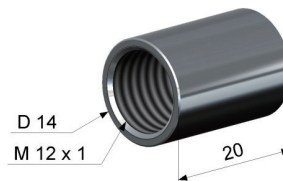

9. Troubleshooting

If problems arise, please check the following suggestions.

Problem	Possible Cause and Solution						
No output	<ul style="list-style-type: none"> • No power. Ensure that the power is being supplied properly. • Wiring may be incorrect. Check the wiring. 						
Abnormal temperature	<ul style="list-style-type: none"> • Wiring may be incorrect. Check the wiring. • Sensor may be disconnected. Check if the sensor is conducting properly. • Lens may be dirty. Remove any dirt on the lens. Always keep the lens clean. Foreign particles on the lens affect measurement accuracy. • Set values such as emissivity, average time, peak hold time, etc. may be set to incorrect values. Check each value. 						
ERR is indicated.	<ul style="list-style-type: none"> • Error messages are indicated. (Backlight: Green) Confirm the character (and its contents) following ERR. <p>For the error messages, see (Table 7-1, p.27). (e.g.)</p> <table border="1" data-bbox="565 1071 1214 1229"> <thead> <tr> <th data-bbox="565 1071 756 1108">LCD Display</th> <th data-bbox="759 1071 1214 1108">Contents</th> </tr> </thead> <tbody> <tr> <td data-bbox="565 1111 756 1148">ERR24</td> <td data-bbox="759 1111 1214 1188">2: Electronics module low temperature</td> </tr> <tr> <td data-bbox="565 1151 756 1188"></td> <td data-bbox="759 1191 1214 1228">4: Sensing head low temperature</td> </tr> </tbody> </table>	LCD Display	Contents	ERR24	2: Electronics module low temperature		4: Sensing head low temperature
LCD Display	Contents						
ERR24	2: Electronics module low temperature						
	4: Sensing head low temperature						

10. Key Operation Flowchart

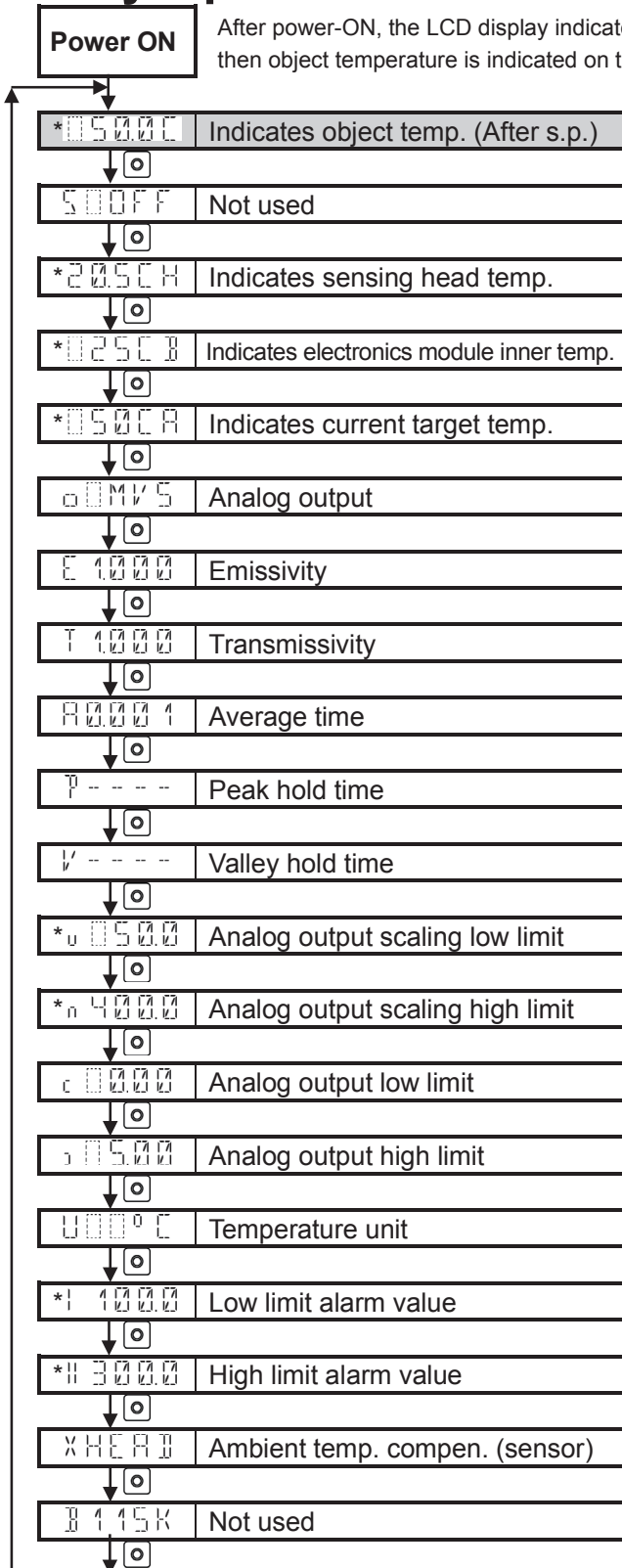

After power-ON, the LCD display indicates `.I.N.I.T` for several seconds, then object temperature is indicated on the LCD display.

Abbreviations:
 Temp.: Temperature
 (After s.p.): (After signal processing)
 Compen.: Compensation

* These values are examples only.

- Key operation:**
- By pressing the key, the instrument proceeds to the next setting item.
 - Use the or key to set items.
 - If 10 seconds elapse with no selection made, the instrument automatically returns to `0500C` [Indicates object temperature (after signal processing)].
 - If the key is pressed again, the instrument will revert to the last setting item.

11. Character Table

Photocopiable material

Display	Name, Setting Range	Factory Default	Data
050.0C (Example)	Indicates object temperature (After signal processing)		
500FF	Not used		
205CH (Example)	Indicates sensing head temperature		
025C8 (Example)	Indicates electronics module inner temperature		
050CA (Example)	Indicates current target temperature		
00MV5	Analog output 00MV5: 0 to 5 V DC 00-20: 0 to 20 mA DC 04-20: 4 to 20 mA DC 00TCK: Thermocouple K. 00TCJ: Thermocouple J. 0MV10: 0 to 10 V DC	0 to 5 V DC	
E 1000	Emissivity 0.100 to 1.100	1.000	
T 1000	Transmissivity 0.100 to 1.100	1.000	
A0001	Average time A-----: OFF 0.001 to 999.9 seconds	0.001 seconds	
P-----	Peak hold time P-----: OFF 0.001 to 999.8 seconds P0000: ∞	OFF	
V-----	Valley hold time V-----: OFF 0.001 to 999.8 seconds V0000: ∞	OFF	
00500 (Example)	Analog output scaling low limit Temperature range low limit to [Analog output scaling high limit – 20.0 °C]	(Table 11-2, p.36)	
n 4000 (Example)	Analog output scaling high limit [Analog output scaling low limit + 20.0 °C] to Temperature range high limit	(Table 11-2, p.36)	

Display	Name, Setting Range	Factory Default	Data										
000.00	Analog output low limit Setting range differs depending on the selection in [Analog output]. (Table 11-1)	0.00 V DC											
	<table border="1"> <thead> <tr> <th>Analog output</th> <th>Setting range</th> </tr> </thead> <tbody> <tr> <td>0 to 5 V DC</td> <td>0.00 to 5.00 V DC</td> </tr> <tr> <td>0 to 20 mA DC</td> <td>0.00 to 20.00 mA DC</td> </tr> <tr> <td>4 to 20 mA DC</td> <td>4.00 to 20.00 mA DC</td> </tr> <tr> <td>0 to 10 V DC</td> <td>0.00 to 10.00 V DC</td> </tr> </tbody> </table>	Analog output	Setting range	0 to 5 V DC	0.00 to 5.00 V DC	0 to 20 mA DC	0.00 to 20.00 mA DC	4 to 20 mA DC	4.00 to 20.00 mA DC	0 to 10 V DC	0.00 to 10.00 V DC		
Analog output	Setting range												
0 to 5 V DC	0.00 to 5.00 V DC												
0 to 20 mA DC	0.00 to 20.00 mA DC												
4 to 20 mA DC	4.00 to 20.00 mA DC												
0 to 10 V DC	0.00 to 10.00 V DC												
005.00	Analog output high limit Setting range differs depending on the selection in [Analog output]. Setting range: The same as Analog output low limit. See (Table 11-1) above.	5.00 V DC											
000 °C	Temperature unit 000 °C: °C 000 °F: °F	°C											
100.00	Low limit alarm value RD-622-LM: -50.0 to 400.0 °C RD-675-HM: 150.0 to 1000 °C	(Table 11-3)											
0300.00	High limit alarm value RD-622-LM: -50.0 to 400.0 °C RD-675-HM: 150.0 to 1000 °C	(Table 11-3)											
X HEAD	Ambient temperature compensation (sensor) X HEAD: Sensing head temperature (automatically compensates using the sensor inner temperature.) RD-622-LM: -50.0 to 605.0 °C (-58.0 to 1121 °F) RD-675-HM: -50.0 to 1010 °C (-58.0 to 1850 °F)	Sensing head temperature											
0115K	Not used												

(Table 11-2)

Model	Factory Default	
	Analog Output Scaling Low Limit	Analog output Scaling High Limit
RD-622-LM	50.0 °C	400.0 °C
RD-675-HM	150.0 °C	1000 °C

(Table 11-3)

Model	Factory Default	
	Low limit alarm value	High limit alarm value
RD-622-LM	100.0 °C	300.0 °C
RD-675-HM	350.0 °C	600.0 °C

Appendix A: Emissivity Table: Metals

Material		Typical Emissivity			
Spectral Response		1.0 μm	1.6 μm	5.1 μm	8-14 μm
Aluminium	Unoxidized	0.1-0.2	0.02-0.2	0.02-0.2	0.02-0.1
	Polished	0.1-0.2	0.02-0.1	0.02-0.1	0.02-0.1
	Roughened	0.2-0.8	0.2-0.6	0.1-0.4	0.1-0.3
	Oxidized	0.4	0.4	0.2-0.4	0.2-0.4
Brass	Polished	0.35	0.01-0.05	0.01-0.05	0.01-0.05
	Roughened	0.65	0.4	0.3	0.3
	Oxidized	0.6	0.6	0.5	0.5
Copper	Polished	0.05	0.03	0.03	0.03
	Roughened	0.05-0.2	0.05-0.2	0.05-0.15	0.05-0.1
	Oxidized	0.2-0.8	0.2-0.9	0.5-0.8	0.4-0.8
Chrome		0.4	0.4	0.03-0.3	0.02-0.2
Gold		0.3	0.01-0.1	0.01-0.1	0.01-0.1
Haynes	Alloy	0.5-0.9	0.6-0.9	0.3-0.8	0.3-0.8
Inconel	Electrolytically polished	0.2-0.5	0.25	0.15	0.15
	Sandblast	0.3-0.4	0.3-0.6	0.3-0.6	0.3-0.6
	Oxidized	0.4-0.9	0.6-0.9	0.6-0.9	0.7-0.95
Iron	Unoxidized	0.35	0.1-0.3	0.05-0.25	0.05-0.2
	Rusted		0.6-0.9	0.5-0.8	0.5-0.7
	Oxidized	0.7-0.9	0.5-0.9	0.6-0.9	0.5-0.9
	Forged, blunt	0.9	0.9	0.9	0.9
	Molten	0.35	0.4-0.6		
Iron, casted	Unoxidized	0.35	0.3	0.25	0.2
	Oxidized	0.9	0.7-0.9	0.65-0.95	0.6-0.95

Material		Typical Emissivity			
Spectral Response		1.0 μm	1.6 μm	5.1 μm	8-14 μm
Lead	Polished	0.35	0.05-0.2	0.05-0.2	0.05-0.1
	Roughened	0.65	0.6	0.4	0.4
	Oxidized		0.3-0.7	0.2-0.7	0.2-0.6
Magnesium		0.3-0.8	0.05-0.3	0.03-0.15	0.02-0.1
Mercury			0.05-0.15	0.05-0.15	0.05-0.15
Molybdenum	Unoxidized	0.25-0.35	0.1-0.3	0.1-0.15	0.1
	Oxidized	0.5-0.9	0.4-0.9	0.3-0.7	0.2-0.6
Monel (Ni-Cu)		0.3	0.2-0.6	0.1-0.5	0.1-0.14
Nickel	Electrolytically polished	0.2-0.4	0.1-0.3	0.1-0.15	0.05-0.15
	Oxidized	0.8-0.9	0.4-0.7	0.3-0.6	0.2-0.5
Platinum	Black		0.95	0.9	0.9
Silver		0.04	0.02	0.02	0.02
Steel	Polished plate	0.35	0.25	0.1	0.1
	Rustless	0.35	0.2-0.9	0.15-0.8	0.1-0.8
	Heavy plate			0.5-0.7	0.4-0.6
	Cold-rolled	0.8-0.9	0.8-0.9	0.8-0.9	0.7-0.9
	Oxidized	0.8-0.9	0.8-0.9	0.7-0.9	0.7-0.9
Tin	Unoxidized	0.25	0.1-0.3	0.05	0.05
Titanium	Polished	0.5-0.75	0.3-0.5	0.1-0.3	0.05-0.2
	Oxidized		0.6-0.8	0.5-0.7	0.5-0.6
Wolfram	Polished	0.35-0.4	0.1-0.3	0.05-0.25	0.03-0.1
Zinc	Polished	0.5	0.05	0.03	0.02
	Oxidized	0.6	0.15	0.1	0.1

Appendix B: Emissivity Table: Non-Metals

Material		Typical Emissivity			
Spectral Response		1.0 μm	2.2 μm	5.1 μm	8-14 μm
Asbestos		0.9	0.8	0.9	0.95
Asphalt				0.95	0.95
Basalt				0.7	0.7
Carbon	Unoxidized		0.8-0.9	0.8-0.9	0.8-0.9
	Graphite		0.8-0.9	0.7-0.9	0.7-0.8
Carborundum			0.95	0.9	0.9
Ceramic		0.4	0.8-0.95	0.8-0.95	0.95
Concrete		0.65	0.9	0.9	0.95
Glass	Plate		0.2	0.98	0.85
	Melt		0.4-0.9	0.9	
Grit				0.95	0.95
Gypsum				0.4-0.97	0.8-0.95
Ice					0.98
Limestone				0.4-0.98	0.98
Paint	Non alkaline				0.9-0.95
Paper	Any color			0.95	0.95
Plastic > 50 μm	Non-transparent			0.95	0.95
Rubber				0.9	0.95
Sand				0.9	0.9
Snow					0.9
Soil					0.9-0.98
Textiles				0.95	0.95
Water					0.93
Wood	Natural			0.9-0.95	0.9-0.95

***** Inquiries *****

For any inquiries about this unit, please contact our agency or the vendor where you purchased the unit after checking the following.

[Example]

- Model ----- RD-622-LM
- Serial number ----- No. xxxxxxxxx

In addition to the above, please let us know the details of the malfunction, or discrepancy, and the operating conditions.

SHINKO TECHNOS CO., LTD.
OVERSEAS DIVISION

Head Office: 2-5-1, Senbahigashi, Minoo, Osaka, Japan

URL: <http://www.shinko-technos.co.jp/e/> Tel : +81-72-727-6100

E-mail: overseas@shinko-technos.co.jp Fax: +81-72-727-7006