

... Inquiry ...

For any inquiry of this controller, after checking the following as to the controller, please contact your shop where purchased, or our agency.

- Model [Example] VCM-130-R/E,.F
- Temperature specification 0 to 999°C
- Type of input K
- Option F
- Instrument number No. 000000

In addition to the above, let us know the details of malfunction, if any, and the operating conditions specifically on job site.

For inquiry about the specification change of this products, please contact the agency mentioned below.

**SHINKO TECHNOS CO., LTD.
OVERSEAS DIVISION**

Reg Office : 2-48, 1-Chome, Ina, Minoo, Osaka, Japan
Mail Address: P.O.Box 17, Minoo, Osaka, Japan
Telephone : (0727)21-2781 & 2782

Cable: SHINKO MINOO JAPAN
FAX : (0727) 24-1760

No. VCM11E8 2000.08

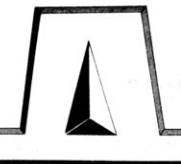

**INSTRUCTION MANUAL
FOR
MICROCOMPUTER BASED
TEMPERATURE INDICATING CONTROLLER**

VCM-100 series

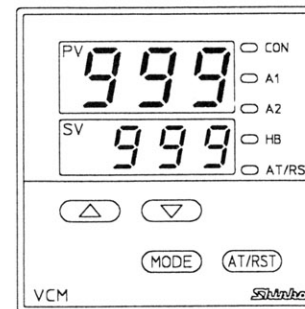

Thank you for your purchase of our Microcomputer based Temperature Indicating Controller VCM-100 series. This manual contains instructions for the mounting, the functions, the operations and the notes when operating the VCM-100 series. For your confirmation of the model and specifications of the controller, peruse and understand this instruction manual before starting operation.

To prevent the accident by mis-handling of this controller, please arrange to give this manual into the hands of the operator who actually uses our product.

• • • Notes to users • • •

Before operating this controller, you should understand about following matters.

 **Warning**

Turn the power supplied to the instrument OFF before wiring or checking. If working or touching the terminal on the power ON status, there is a possibility of Electric Shock which can cause severe injury or death.

 **Notices**

- The instrument must be grounded before the power is turned on.
- Do not operate the keys during warm-up status (for approx. 8 seconds after the power on), and do not turn the power on while the key is pressing, or the specification contents of the instrument will have possibilities to change.
- PID auto-tuning does not function if setting value lock is designated. It is recommended that the PID auto-tuning is performed on the trial run.
- The reset key functions only when the option PD is designated. If it is not designated, the key functions as PID auto-tuning key.
- It is advised to provide the protective device against unexpected event owing to the using condition and aged change of the parts.

- If you start to mount this controller to the control panel or machine, read this manual from the item " 8. Mounting to control panel " or " 9. Wiring connection " after checking the model name by " 1. Model names ".
- If you operate this controller already mounted, read this manual from the item " 2. Name and functions of the sections " or " 3. Operations ".

1. Model names	
1.1 Model names	5
1.2 How to indicate the model nameplate	6
2. Name and functions of the sections	
2.1 Displays	7
2.2 Keys	8
3. Operations	
3.1 Operating flow chart	9
3.2 Operations	
(1) PV/SV display mode	10
(2) Main setting mode	
Main setting mode	10
(3) Sub setting mode	
Proportional band setting mode	11
Integral time setting mode	11
Derivative time setting mode	11
Anti-reset windup setting mode	11
Main control (C1) proportional cycle setting mode	11
Sub control (C2) proportional cycle setting mode	11
Sub control (C2) proportional band setting mode	12
Temperature alarm (A1) setting mode	12
Temperature alarm (A2) setting mode	12
Overlap band/Dead band setting mode	12
Heater burnout alarm setting mode	12
(4) Auxiliary function setting mode	
Setting value lock designation mode	15
Sensor designation mode	15
Scaling high limit setting mode	16
Scaling low limit setting mode	16
Output high limit setting mode	16
Output low limit setting mode	16
Sensor correction setting mode	17
Control type designation mode	17
Temperature alarm (A1) action designation mode	17
Temperature alarm (A2) action designation mode	18
Main control (C1) differential setting mode	18
Sub control (C2) differential setting mode	18
(5) Control output OFF function	18
4. Running	19
5. Action explanations	
5.1 Standard action drawings	20
5.2 Heater burnout alarm action drawing	20
5.3 Heating/Cooling action drawings	21
5.4 Heating/Cooling action drawings (setting dead band)	22
5.5 Temperature alarm (A1, A2) action drawings	23
5.6 ON/OFF action drawings (setting prop. band to 0.0)	24

6. Control actions 25
 6.1 Explanations of PID and ARW 25
 6.2 PID auto-tuning of this controller 26

7. Other functions 27

8. Mounting to control panel 28
 8.1 Site selection 28
 8.2 External dimension drawing 28
 8.3 Panel cutout drawing 28
 8.4 Current transformer (CT) dimension drawing 28

9. Wiring connection 31
 9.1 Terminal arrangements 29
 9.2 Wiring connection examples 31

10. Specifications 34
 10.1 Standard specifications 32
 10.2 Optional specifications 34

11. When troubled 36

12. Character table 37

1. Model names

1.1 Model names

Alphanumeric character to represent the functions or type is applied to the □.

[Example] VCM-13 2 - R / E , W ,

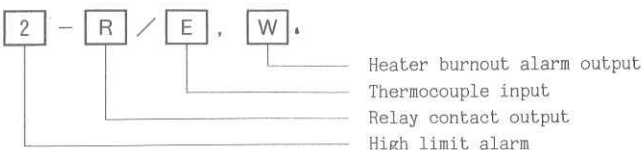

◆ Standard models

VCM-1	3	□-□/□	Series name: VCM-130 series
Control action	3		PID action (with auto-tuning function)
Temperature alarm action	0		No alarm action
	2		High limit alarm
	3		Low limit alarm
	4		High/low limits alarm
	6		High/low limit range alarm
Output	8		Process value alarm
	R		Relay contact 1c
	S		Non-contact voltage 15±3Vdc (for SSR drive)
Input	A		DC Current 4 to 20mAdc
	E		Thermocouple K, J
	R		RTD Pt100, JPt-100

◆ Optional code

Code	Description
H	Temperature alarm (A1) output with standby function
AL□	Temperature alarm (A2) output AL2, AL3, AL4, AL6, AL8
AL□H	Temperature alarm (A2) output with standby function AL2H, AL3H, AL4H
D□	Heating/Cooling control output (Relay contact: DR) (Non-contact voltage: DS) Heating control (reverse): Main control (C1) output Cooling control (direct): Sub control (C2) output
W	Heater burnout alarm output (including Sensor burnout alarm)
CM	Cooling action
SK	Specified hysteresis
F	Function selection
PD	PD control action (with auto-reset function)
BK	Color black, Faceplate: Dark-gray
TC	Terminal cover

See page 34 for the contents of the options in detail.

1.2 How to indicate the model nameplate

Model nameplates are put on the right side of the case and the left side of the inner assembly.

	Model nameplate	[Example]
① →	130-R/E	↔ Relay output/Thermocouple input
② → {	F	↔ Function selection
	W (10A)	↔ Heater burnout alarm (10A)
③ →	No.	

- ① Model name
 ② Option codes, Special order No.
 ③ Serial No. (Indicated only inner assembly)

• In case the option has the specified value, it is entered in ().

Warning

Do not take the inner assembly out or touch the terminal when the power supply is ON status. If you touch the terminal, there is possibility of Electric Shock which can cause severe injury or death.

2. Name and functions of the sections

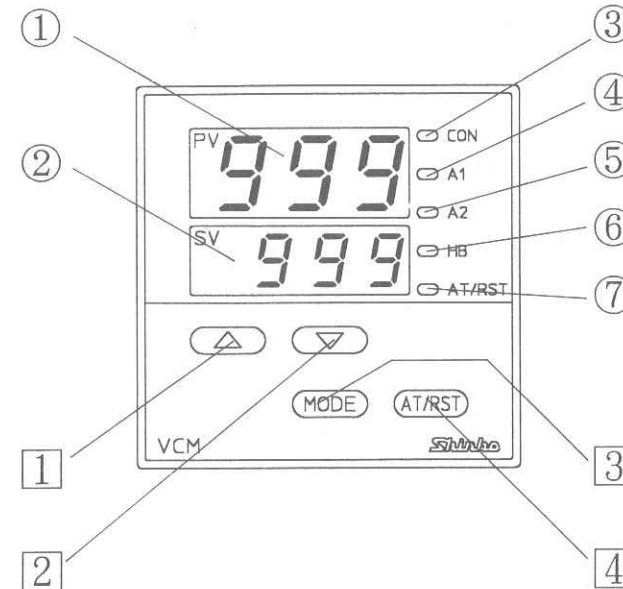

2.1 Displays

- | | |
|---|--|
| ① Process variable (PV) display | It indicates the Process variable. (Red LED) |
| ② Setting value (SV) display | It indicates the Setting value. (Green LED) |
| ③ <input type="checkbox"/> CON Main control (C1) output or Heating control [Option] output indicator | Green LED lights when the Main control output (C1) is ON, or Heating control output is ON. (In case of current output type, it always lights.) |
| ④ <input type="checkbox"/> A1 Temperature alarm (A1) output indicator | Red LED lights when Temperature alarm (A1) output is ON. |
| ⑤ <input type="checkbox"/> A2 Temperature alarm (A2) output indicator [option] or Sub control output indicator [option] | Red LED lights when Temperature alarm (A2) output is ON, or Sub control output (C2) is ON. |
| ⑥ <input type="checkbox"/> HB Heater burnout alarm output [Option], Sensor burnout alarm output or Temperature alarm (A2) output indicator [Option] | Red LED lights when Heater burnout alarm output is ON, or Sensor burnout alarm output is ON. When both outputs Sub control (C2) and Temperature alarm (A2) is applied, it lights when the Temperature alarm output (A2) is ON. |
| ⑦ <input type="checkbox"/> AT/RST PID auto-tuning action indicator or PD auto-reset action [Option] indicator | Yellow LED blinks during PID auto-tuning, or during PD auto-reset (offset correction). |

2.2 Keys

Main function of each key is described here, however, the key has other functions on the mode. Refer to the item " 3. Operation " (Page 9 ff).

- 1 **▲** Increase key : It increases the setting value (SV) being displayed. Continuous pressing makes the value change faster.
 - 2 **▼** Decrease key : It decreases the setting value (SV) being displayed. Continuous pressing makes the value change faster.
 - 3 **(MODE)** Mode key : It selects the setting mode.
 - 4 **(ARST)** PID auto-tuning key/PD auto-reset key
 - **PID auto-tuning key**
It performs or cancels the PID auto-tuning.
 - **PD auto-reset key**
When the controlling value is within the proportional band, if this key is pressed for 1 second or more, the controller starts offset correction. (It functions only when option PD is designated.)
When the indicator is blinking, this reset key cannot be accepted.
- In any mode, PID auto-tuning will be started by pressing the **(ARST)** key. It will not start if lock is specified by Setting value lock designating mode (See page 15).
If the **(ARST)** key is pressed by mistake, press the key again to cancel the tuning.
 - The setting value is registered by pressing the **(MODE)** key. If it is left without the key operation for approx. 30 seconds, the mode will return to PV/SV display mode automatically and the values left will be registered.

3. Operations

3.1 Operating flow chart

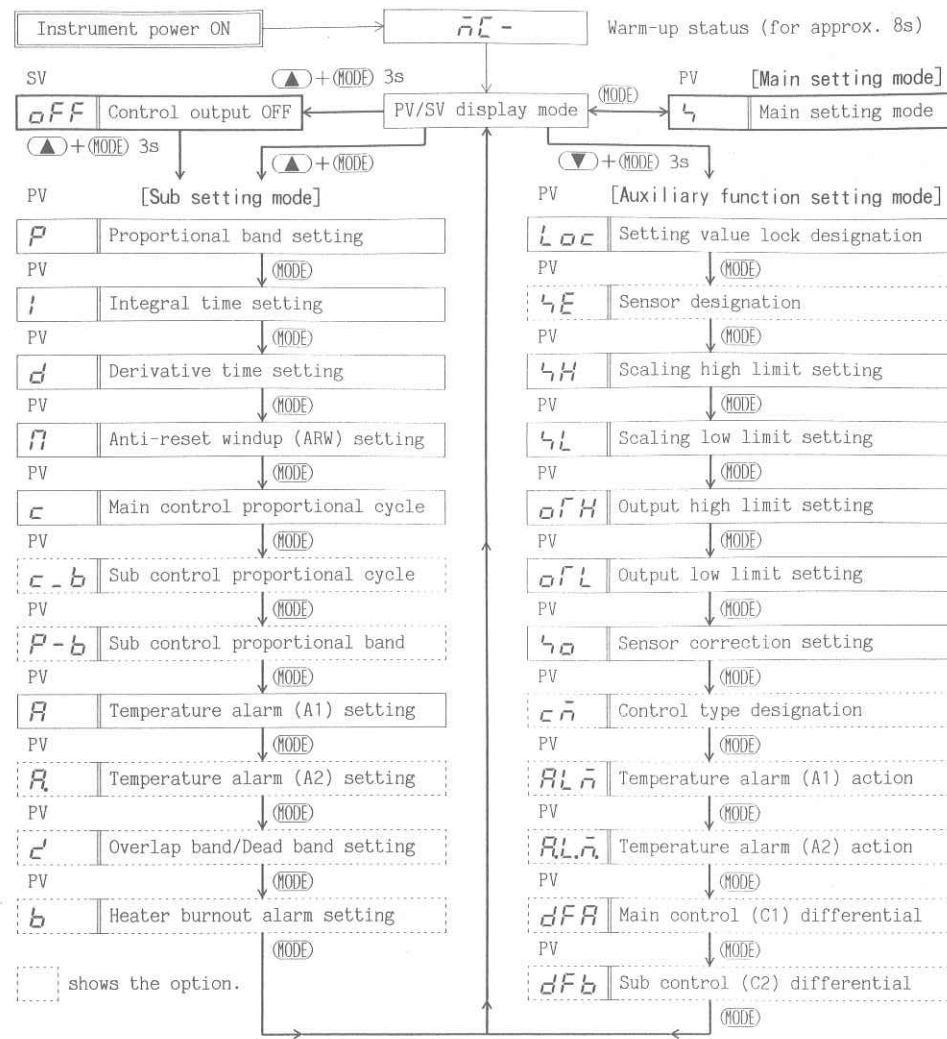

- [Notes] **▲**+(MODE) : Press the **(MODE)** key while the **▲** key is being pressed.
▲+(MODE) 3s: Press the keys until [OFF] is displayed (for approx. 3 seconds).
▼+(MODE) 3s: Press the keys until [Loc] is displayed (for approx. 3 seconds).

3.2 Operations

Process variable display (PV) indicates [$\bar{n} \bar{c}$ -] for approx. 8 seconds after the power is turned ON. During this time, all outputs, (SV) display and LED indicators are in their off status. After that, it displays actual temperature on the PV display, setting value on the SV display and starts control.

Notice

Do not operate the keys during warm-up status (for approx. 8 seconds after the power on), and do not turn the power on while the key is pressing, or the specification contents of the instrument will have possibilities to change.

(1) PV/SV display mode

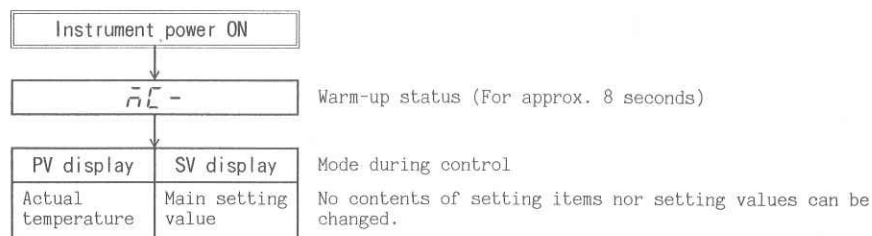

(2) Main setting mode

The setting value can be increased or decreased by pressing the \blacktriangle or \blacktriangledown key. If the (MODE) key is pressed, the setting value is registered and the mode returns to PV/SV display mode.

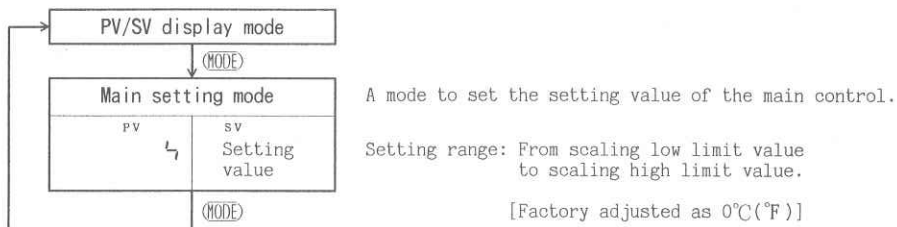

(3) Sub setting mode

Sub setting mode can be selected, if the (MODE) key is pressed while the \blacktriangle key is being pressed. The setting value can be increased or decreased by pressing the \blacktriangle or \blacktriangledown key. If the (MODE) key is pressed, the setting value is registered and the setting mode is changed.

- When the PID auto-tuning is performed, the values P, I, D and ARW are set automatically.
- Setting the proportional band value to 0.0 causes the instrument to act as an ON/OFF controller.
- Setting the integral time or derivative time to 0 disables the function.
- In case one of the option AL2 to AL8 is not applied, the temperature alarm (A2) setting mode is not available.
- If the option DR or DS is not applied, Sub control (C2) output proportional cycle setting mode, Sub control (C2) output proportional band setting mode and Overlap band/Dead band setting mode is not available.
- When the option W is not applied, heater burnout alarm setting mode is not available.

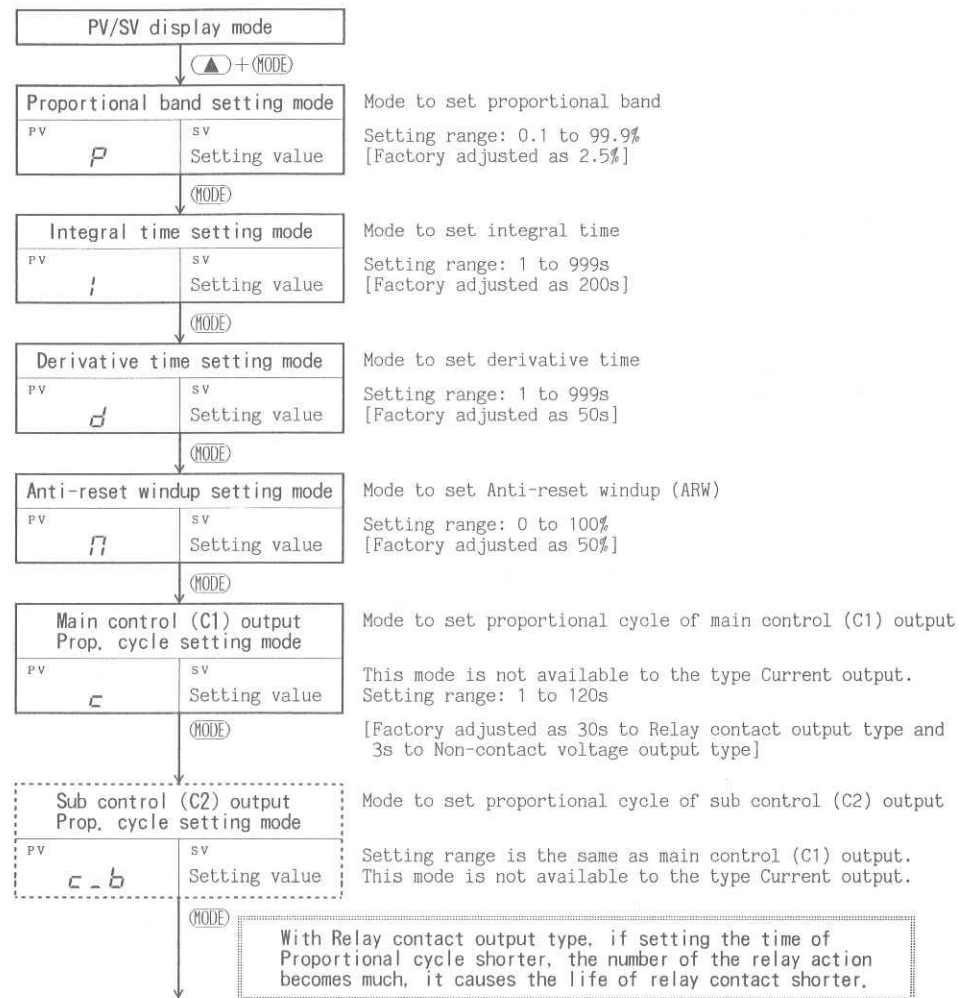

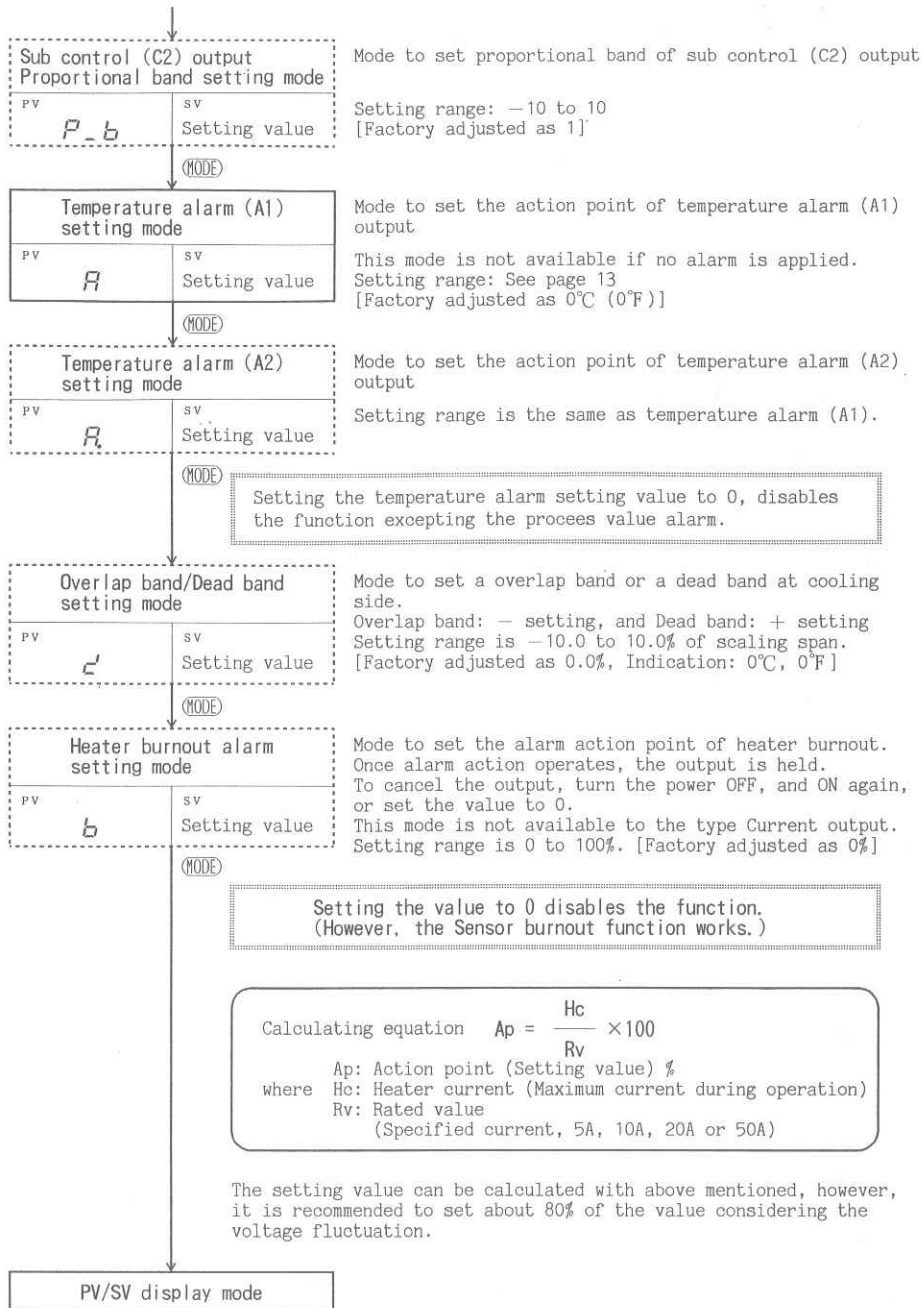

● Heating/Cooling control output action drawings

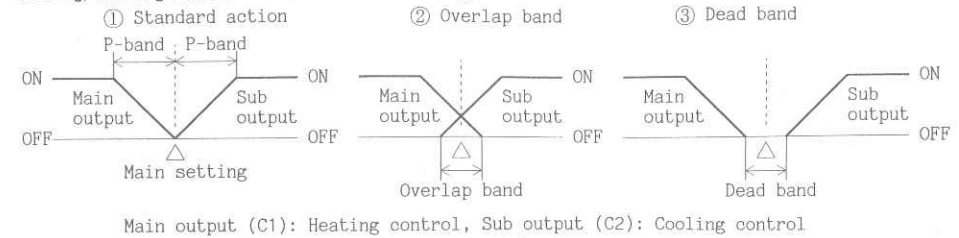

● Setting ranges of the temperature alarms are as follows.

High limit alarm	-100 to 100°C	[-199 to 200°F]
Low limit alarm	-100 to 100°C	[-199 to 200°F]
High/Low limits alarm	±(1 to 100)°C	[1 to 200°F, -1 to -199°F] *1
High/Low limit range alarm	±(1 to 100)°C	[1 to 200°F, -1 to -199°F] *1
Process value alarm	Scaling low to high limit setting value	

● In case decimal point is applied (RTD input)

High limit alarm	-19.9 to 99.9°C	[-19.9 to 99.9°F]
Low limit alarm	-19.9 to 99.9°C	[-19.9 to 99.9°F]
High/Low limits alarm	±(1.0 to 99.9)°C	[±(1.0 to 99.9)°F] *1, *2
High/Low limit range alarm	±(0.1 to 99.9)°C	[±(0.1 to 99.9)°F] *1
Process value alarm	Scaling low to high limit setting value	

*1: The same values are set to the both sides (+ and -).

*2: Related to the hysteresis, avoid setting 0.9 or less, or the normal action will be disturbed.

● Temperature alarm with standby function (Option code: H)

When power is applied to the controller, the function disables alarm action even if the input value is in the range in which the alarm action works, and this also prevents the alarm even if the alarm action point enters the above range as a result of the main setting value change during control. Once the input value exceeds the alarm action point continuing the control, the standby function will be released and when the input value reaches the point again, the alarm action output will work.

● Setting ranges of the temperature alarms are as follows.

High limit alarm with standby function	: -100 to 100°C	[-199 to 200°F]
Low limit alarm with standby function	: -100 to 100°C	[-199 to 200°F]
High/Low limits alarm with standby function	: ±(1 to 100)°C	[1 to 200°F, -1 to -199°F] *1

● In case decimal point is applied (RTD input)

High limit alarm with standby function	: -19.9 to 99.9°C	[-19.9 to 99.9°F]
Low limit alarm with standby function	: -19.9 to 99.9°C	[-19.9 to 99.9°F]
High/Low limits alarm with standby function	: ±(1.0 to 99.9)°C	[±(1.0 to 99.9)°F] *1, *2

*1: The same values are set to the both sides (+ and -).

*2: Related to the hysteresis, avoid setting 0.9 or less, or the normal action will be disturbed.

● Example to set the Sub control (C2) proportional band

In case, Rated scale is 0 to 400°C,

Main control (C1) proportional band is 10.0% (40°C),

Desired Sub (C2) proportional band is 8°C.

Set the Sub control (C2) proportional band setting value to -5 (See the below table.)

Calculating equation $Spv = Mpv \times Spf$

Spv: Proportional band of Sub (C2) control output
 where Mpv: Proportional band of Main (C1) control output
 Spf: Proportional band setting value (multiplying factor) of Sub (C2) control output

When the Proportional band setting value of the Sub control (C2) is -5, the multiplying factor is 1/5, therefore, the value is calculated as 40°C × 1/5 = 8°C.

Sub control Proportional band setting value	-10	-9	-8	-7	-6	-5	-4	-3	-2	-1	0
Sub control Proportional band multiplying factor	1/10	1/9	1/8	1/7	1/6	1/5	1/4	1/3	1/2	1/1	0
Sub control Proportional band value (°C) [*]	4.0	4.4	5.0	5.7	6.7	8.0	10.0	13.3	20.0	40.0	0

Sub control Proportional band setting value	0	1	2	3	4	5	6	7	8	9	10
Sub control Proportional band multiplying factor	0	1	2	3	4	5	6	7	8	9	10
Sub control Proportional band value (°C) [*]	0	40	80	120	160	200	240	280	320	360	400

[*] The value is in case the rated scale is 0 to 400°C for the example.

(4) Auxiliary function setting mode

Auxiliary function setting mode can be selected if the (MODE) key is pressed for approx. 3 seconds while the (▼) key is being pressed.

The designation or setting value can be increased or decreased by pressing the (▲) or (▼) key. If the (MODE) key is pressed, the designation or setting value is registered and the setting mode is changed.

If the option (code: F) is not applied, the modes: Sensor designation, Control type designation, Temperature alarm (A1) action designation, Temperature alarm (A2) action designation and Main control (C1) differential setting are not available.

If the options (code: DR or DS) and (code: F) are not applied, Sub control (C2) differential setting mode is not available.

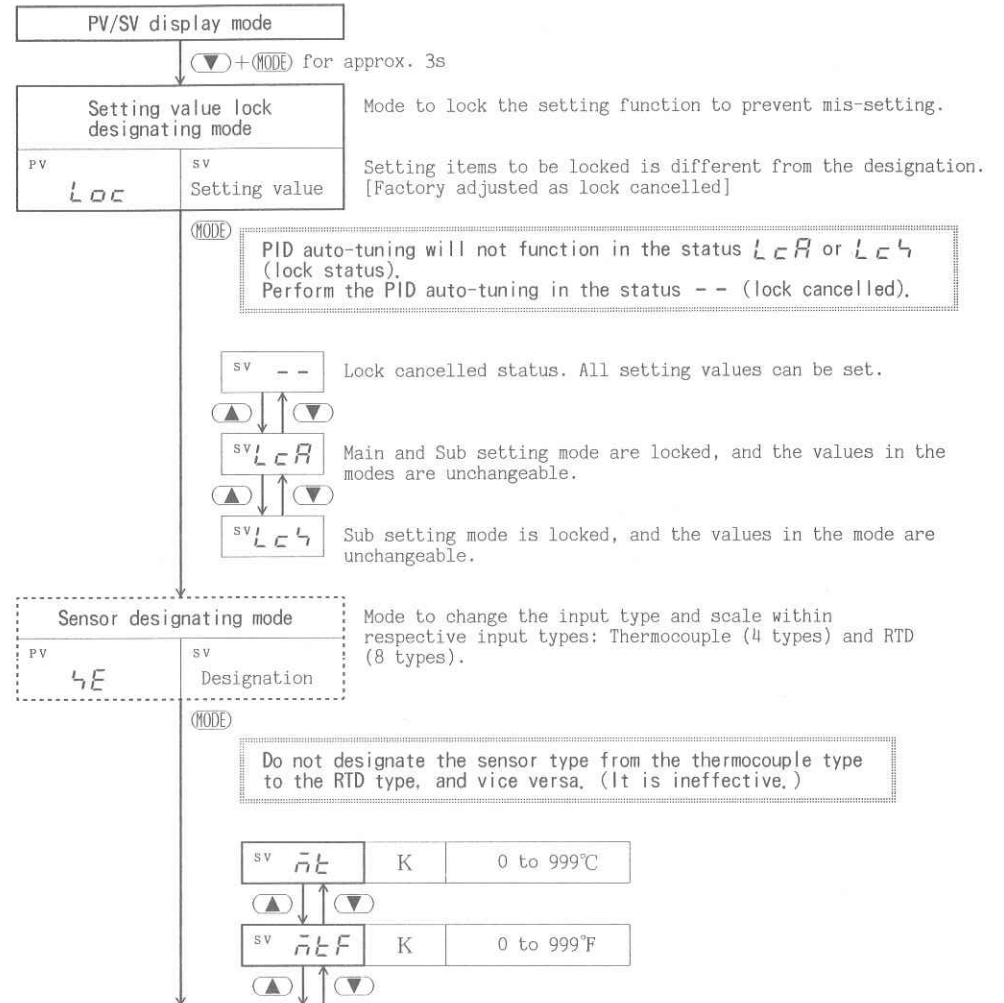

SV	SV	J	0 to 800°C
SV	SV	J	0 to 999°F
SV	JPL100		199 to 400°C
SV	JPL100		-199 to 999°F
SV	Pt100		-199 to 400°C
SV	Pt100		-199 to 999°F
SV	JPt100		-19.9 to 99.9°C
SV	JPt100		-19.9 to 99.9°F
SV	Pt100		-19.9 to 99.9°C
SV	Pt100		-19.9 to 99.9°F

Scaling high limit setting mode		Mode to set the high limit of the scale value.
PV	SV	Setting range is different from the type of sensor. [Factory adjusted as specified]
4H	Setting value	
(MODE)		
Scaling low limit setting mode		Mode to set the low limit of the scale value.
PV	SV	Setting range is different from the type of sensor. [Factory adjusted as specified]
4L	Setting value	
(MODE)		
Output high limit setting mode		Mode to set the high limit of the control output.
PV	SV	Setting range: Output low limit value to 100%. [Factory adjusted as 100%] (Indication: to 110%)
oFH	Setting value	
(MODE)		
Output low limit setting mode		Mode to set the low limit of the control output.
PV	SV	Setting range: 0% to Output high limit value [Factory adjusted as 0%] (Indication: from -10%)
oFL	Setting value	
(MODE)		

Sensor correction setting mode		Mode to set the correction value of the sensor.
PV	SV	Setting range: -19.9 to 30.0°C [-19.9 to 50.0°F] [Factory adjusted as 0.0°C(°F)]
40	Setting value	
(MODE)		
Control type designating mode		Mode to designate the control type (Heating [reverse] or Cooling [direct]).
PV	SV	[Factory adjusted as Heating]
cñ	Designation	
(MODE)		
SV	Heating (reverse) action	
SV	Cooling (direct) action	
(MODE)		
Temperature alarm (A1) action designating mode		Mode to designate the temperature alarm (A1) action.
PV	SV	Designation
RLñ	Designation	
(MODE)		
SV	No alarm action	
SV	High limit alarm action	
SV	Low limit alarm action	
SV	High/Low limits alarm action *	
SV	Hi/Lo limit range alarm action *	
SV	High limit alarm with standby	
SV	Low limit alarm with standby	
SV	Hi/Lo limits alarm w/standby *	
SV	Process value alarm	
(MODE)		

*: The same values are set to the both sides (+ and -).

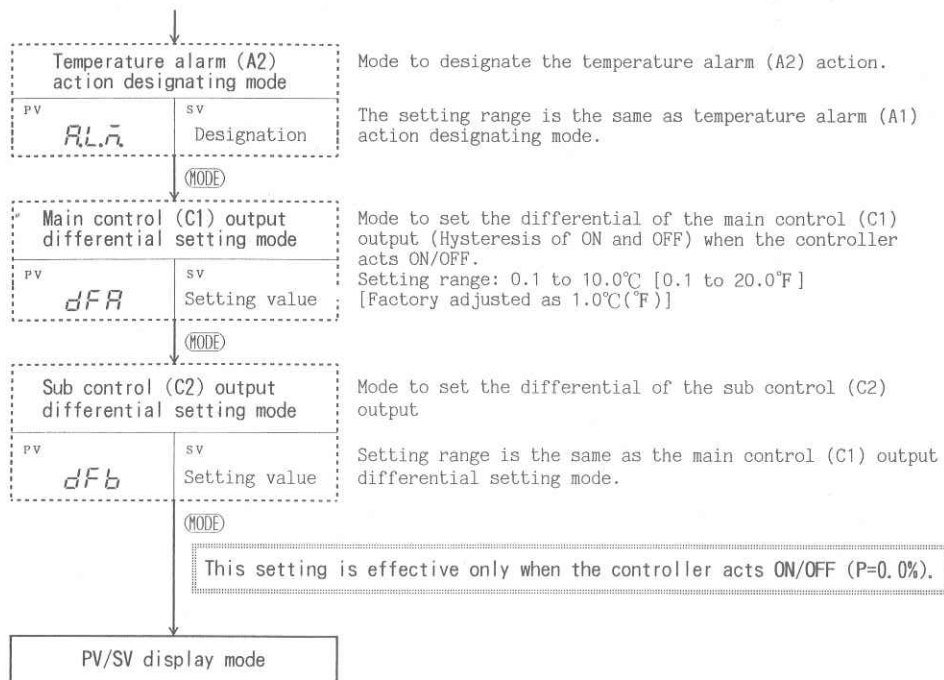

This setting is effective only when the controller acts ON/OFF (P=0.0%).

• Explanation of the sensor correction function

It corrects the input value from the sensor. When a sensor cannot be set at a location where control is desired, the sensor measuring temperature may deviate from the temperature in the controlled location. When controlling with plural controllers, the accuracy of sensors have influence on the control. Therefore, sometimes measuring temperature (input value) does not accord with the same setting value. In such a case, the control can be accorded with desired temperature by shifting the input value of sensors.

(5) Control output OFF function

A function to make the control output OFF even the power to the instrument is supplied. The function is used when required to halt the control action or the VCM-100 is not used in plural controllers. When the function is working, SV display indicates [OFF].

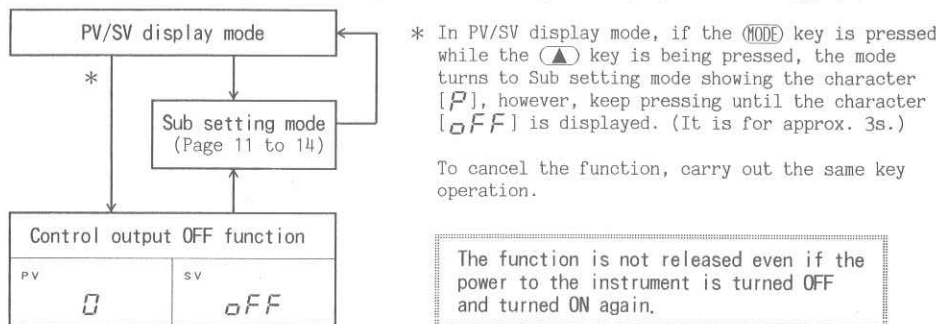

The function is not released even if the power to the instrument is turned OFF and turned ON again.

4. Running

After completion of the mounting to the control panel and wiring connections, start running in the following manner:

- (1) Turn the power supplied to this instrument VCM-130 ON.
- (2) For approx. 8s after the power on, [rL-] is displayed on process variable display. During this time, all outputs, setting value display and LED indicators are in their OFF status. After that, it displays actual temperature on the process variable display, setting value on the display, and starts the control.

⚠ Notice

Do not operate the keys during warm-up status (for approx. 8 seconds after the power on), and do not turn the power on while the key is pressing, or the specification contents of the instrument will have possible to change.

- (3) Input the setting value, referring to item "3. Operation" (page 9 ff).
- (4) Turn the load circuit power ON.
- (5) It starts the control action so as to maintain the controlled object at the setting value.

• PID auto-tuning performance and cancellation

• PID auto-tuning performance

PID auto-tuning is started by pressing the (AT/ST) key, and auto-tuning indicator (Yellow LED) blinks. The (MODE) key turns into ineffective during auto-tuning and other settings cannot be set in this status.

When the auto-tuning ends, the indicator will go off and the Proportional band (P), Integral time (I), Derivative time (D) and ARW value correspond to the controlling process are set automatically.

Each setting value: P, I, D and ARW value can be confirmed or changed by calling each setting mode of sub setting.

• PID auto-tuning cancellation

To cancel the auto-tuning on its process, press the (AT/ST) key again. However, if released from the tuning unfinished, values correspond to the controlling process cannot be gotten, but returns to the former values.

- PID auto-tuning will not function if any lock mode is specified.
- It is recommended that the PID auto-tuning is performed on the trial run.

5. Action explanations

5.1 Standard action drawings

Action		Heating action [HE] (reverse)			Cooling action [CO] (direct)		
Main control action							
Relay contact	Output						
	Indication (Green) [CON]						
Non-contact voltage	Output						
	Indication (Green) [CON]						
Current	Output						
	Indication (Green) [CON]						

5.2 Heater burnout alarm action (Option: W)

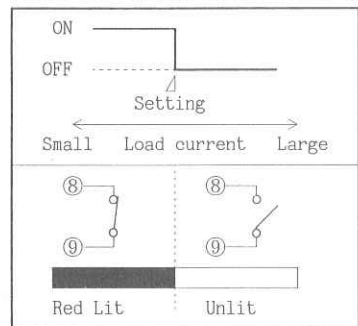

5.3 Heating/Cooling control action drawings [Option: D]]

Control action		Heating (reverse) action [HE]			Cooling (direct) action [CO]		
Heating/Cooling control							
	Relay contact						
Main output (C1)	Indication (CON)						
	Non-contact voltage						
	Current						
Sub output (C2)	Indication (CON)						
	Relay contact						
	Indication (A2)						
Sub output (C2)	Non-contact voltage						
	Indication (A2)						

5.4 Heating/Cooling control action drawings [Option: D] (When setting the dead band.)

Control action	Heating (reverse) action [HE]	Cooling (direct) action [CO]
Heating/Cooling control		
Relay contact	<p>Cycle action is performed according to deviation</p>	<p>Cycle action is performed according to deviation</p>
Main output (C1)	<p>Indication (CON)</p> <p>Green lit Unlit</p>	<p>Unlit Green lit</p>
	<p>Non-contact voltage</p> <p>⑥ + ⑥ + ⑥ + 15Vdc 15/0Vdc 0Vdc ⑦ - ⑦ - ⑦ -</p> <p>Cycle action is performed according to deviation</p>	<p>⑥ + ⑥ + ⑥ + 0Vdc 0/15Vdc 15Vdc ⑦ - ⑦ - ⑦ -</p> <p>Cycle action is performed according to deviation</p>
	<p>Indication (CON)</p> <p>Green lit Unlit</p>	<p>Unlit Green lit</p>
	<p>Current</p> <p>⑥ + ⑥ + ⑥ + 20mAdc 20~4mAdc 4mAdc ⑦ - ⑦ - ⑦ -</p> <p>Changes continuously according to deviation</p>	<p>⑥ + ⑥ + ⑥ + 4mAdc 4~20mAdc 20mAdc ⑦ - ⑦ - ⑦ -</p> <p>Changes continuously according to deviation</p>
Sub output (C2)	<p>Indication (CON)</p> <p>Green lit</p>	<p>Green lit</p>
	<p>Relay contact</p> <p>Cycle action is performed according to deviation</p>	<p>Cycle action is performed according to deviation</p>
	<p>Indication (A2)</p> <p>Unlit Red lit</p>	<p>Red lit Unlit</p>
	<p>Non-contact voltage</p> <p>①⑦ + ①⑦ + ①⑦ + 0Vdc 0/15Vdc 15Vdc ①⑧ - ①⑧ - ①⑧ -</p> <p>Cycle action is performed according to deviation</p>	<p>①⑦ + ①⑦ + ①⑦ + 15Vdc 15/0Vdc 0Vdc ①⑧ - ①⑧ - ①⑧ -</p> <p>Cycle action is performed according to deviation</p>
<p>Indication (A2)</p> <p>Unlit Red lit</p>	<p>Red lit Unlit</p>	

(P): Main control proportional band (DB): Dead band (Pb): Sub control proportional band

5.5 Temperature alarm (A1, A2) action drawings

Alarm type	High limit alarm	Low limit alarm
Temperature alarm action		
Output		
Indication	<p>Unlit Red Lit</p>	<p>Red Lit Unlit</p>
Alarm type	High limit alarm with standby	Low limit alarm with standby
Temperature alarm action		
Output		
Indication	<p>Unlit Red Lit</p>	<p>Red Lit Unlit</p>
Alarm type	High/Low limits alarm	High/Low limit range alarm
Temperature alarm action		
Output		
Indication	<p>Red Lit Unlit Red Lit</p>	<p>Unlit Red Lit Unlit</p>
Alarm type	High/Low limits alarm with standby	Process value alarm
Temperature alarm action		
Output		
Indication	<p>Red Lit Unlit Red Lit</p>	<p>Unlit Red Lit</p>

《Standby function: (hatched)》 (A2 alarm: Terminals ①⑦-①⑧, Option DR or DS: Terminals ⑧-⑨)

6.6 ON/OFF action drawings

In case the proportional band is set to "0.0".

Action	Heating action (reverse) HE	Cooling action (direct) CO	Heating and Cooling control (Option code: DU)	
Main control action	<p>Hysteresis dFA</p> <p>ON</p> <p>OFF</p> <p>Main setting</p>	<p>Hysteresis dFA</p> <p>ON</p> <p>OFF</p> <p>Main setting</p>	<p>Hysteresis Dead band Hysteresis dFA dFB</p> <p>[Heating] Main setting [Cooling]</p> <p>ON</p> <p>OFF</p>	
Relay contact	Output			
	Indication	Green lit Unlit	Unlit Green lit	Green lit Unlit Red lit
Non-contact voltage	Output			
	Indication	Green lit Unlit	Unlit Green lit	Green lit Unlit Red lit
Current	Output			
	Indication	Green lit	Green lit	

In the range , controller acts ON or OFF.

7. Control actions

7.1 Explanations of PID and ARW

(1) Proportional band (P)

Proportional action is the action of which the control output varies in proportion to the deviation between setting value and processing temperature. If the proportional band is narrowed, the output changes according to even by a slight variation of the processing temperature, and better control result can be obtained as the offset decreases. However, if when the proportional band is extremely far too narrowed, it may cause variation in the processing temperature even by slight disturbance, and turns into control such as ON/OFF action of the so called hunting phenomenon.

Therefore, when the processing temperature comes to the balanced position near the setting value and a constant temperature is maintained, the most suitable value is selected by gradually narrowing the proportional band while observing the control results.

(2) Integral time (I)

Integral action is to eliminate offset. When the integral time is shortened, the returning speed to the setting point is quickened. However, the cycle of oscillation is also quickened and stability becomes unfavorable.

(3) Derivative time (D)

Derivative action is to restore the change of processing temperature according to the changing rate. It reduces the amplitude of overshoot and undershoot width.

If the derivative time is shortened, restoring value comes small, and if the derivative time is adjusted longer, a phenomenon of returning too much may occur and the control system may be oscillated.

(4) Anti-reset windup (ARW)

ARW prevents overshoot caused due to the integral action. The less ARW value is, the less excess integral action becomes at transition status, however, it needs time till stabilized. If operating by manual, duty factor of load for the setting is of standard value, to fix controlling aim.

How to get the duty factor for ARW when manual controlling.

In case of relay output or SSR driving output:

$$\text{Duty factor(\%)} = \frac{\text{ON action time}}{\text{Proportional cycle}} \times 100 (\%)$$

In case of current output:

$$\text{Duty factor(\%)} = \frac{\text{Output current (mA)} - 4}{16} \times 100 (\%)$$

- Set to 50% (the same as factory adjusted), if duty factor is unknown.
- Each value, PID and ARW are automatically set after auto-tuning.

6.2 PID auto-tuning of this instrument

In order to decide each value of P, I, D and ARW automatically, this system gives the fluctuation to the control object by force. Three kinds of undermentioned systems are automatically selected by an instrument.

- (1) In case the difference between setting value and processing temperature is large when the temperature rises.
Fluctuation is given at the temperature 5% of scaling span less than the setting value.

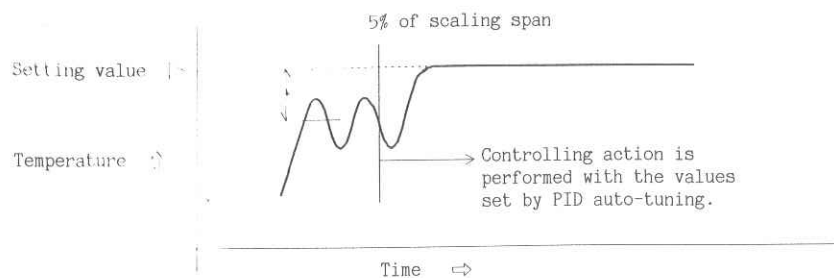

- (2) In case of the stable situation during control or when control temperature is within $\pm 10\%$ of scaling span.

Fluctuation is given at the setting value.

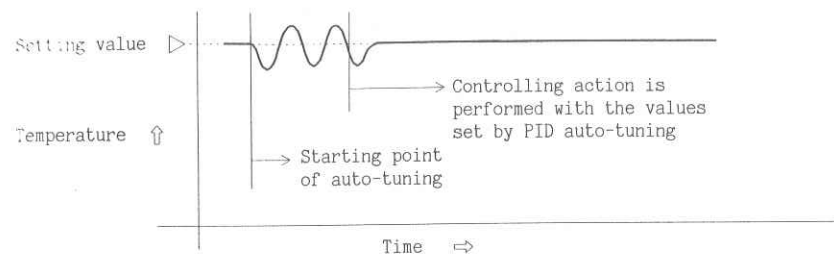

- (3) In case control temperature is 10% or more of scaling span higher than the setting value.

Fluctuation is given at the temperature 5% of scaling span higher than the setting value.

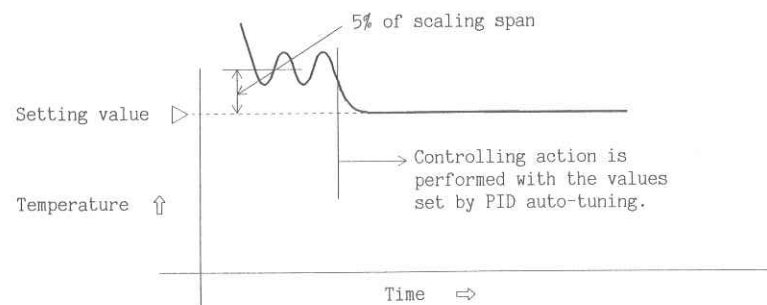

7. Other functions

(1) Tamper-proof function

In any mode excepting PV/SV display mode, if no keys are pressed for approx. 30s, the controller will automatically return to PV/SV display mode, and the values and the designated items are registered.

(2) Burnout alarm (upscale)

When the thermocouple or RTD (between A and B) is burnt out or input value exceeds 1.125 times as much as the rated scale high limit value, PV display blinks [- - -] and HB indicator (red) lights.

At this time, in case the main control (C1) is Heating (reverse) action, it makes the output to OFF, and in case the control is Cooling (direct), it makes the output to ON. In case heater burnout alarm function is specified, the alarm output is added and heater burnout alarm output turns ON as sensor burnout alarm output.

(3) Self-diagnostic function

It watches the CPU by watchdog timer, and when any abnormal status is found on the CPU, it makes the controller to warm-up status [- - -] by making the all output off.

(4) Automatic cold junction temperature compensation (Thermocouple type)

It detects the temperature at the connecting terminal between thermocouple and instrument and always makes it the same status at which the reference junction located at 0°C [32°F].

8. Mounting to control panel

8.1 Site selection

Mount the controller in a place with:

- (1) A minimum of dust, and an absence of corrosive gases.
- (2) No mechanical vibrations or shocks.
- (3) No exposure to direct sunlight, and an ambient temperature is 0°C to 50°C (32 to 122°F), and it does not change suddenly.
- (4) An ambient humidity is 85%RH or less, and non-condensing.
- (5) The controller should be away from the electromagnetic switch of large capacity, or cables through which large current flows.
- (6) No water, oil or chemicals and their vapor directly splash.

8.2 External dimension drawing (Mounting panel thickness is 1 to 8mm.)

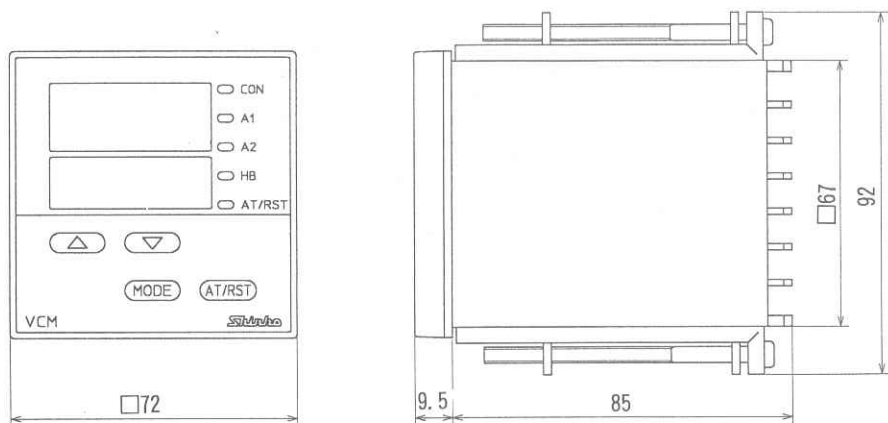

Notice
Do not screw with excessive force, or the case may be bent, since it is made of resin. Fastening torque is approx. 0.4N·m.

8.3 Panel cutout drawing

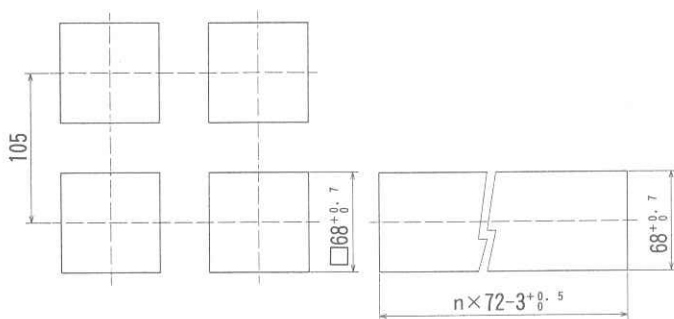

Lateral close mounting
n: Number of units installed

Accessory for Option: W

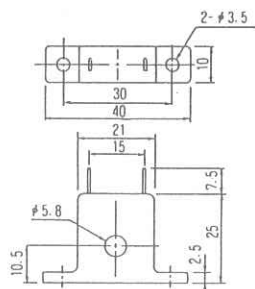

Current transformer for
[Heater burnout alarm]

9. Wiring connection

Warning

Turn the power supplied to the instrument OFF before wiring or checking. If working or touching the terminal on the power ON status, there is a possibility of Electric Shock which can cause severe injury or death.

9.1 Terminal arrangements

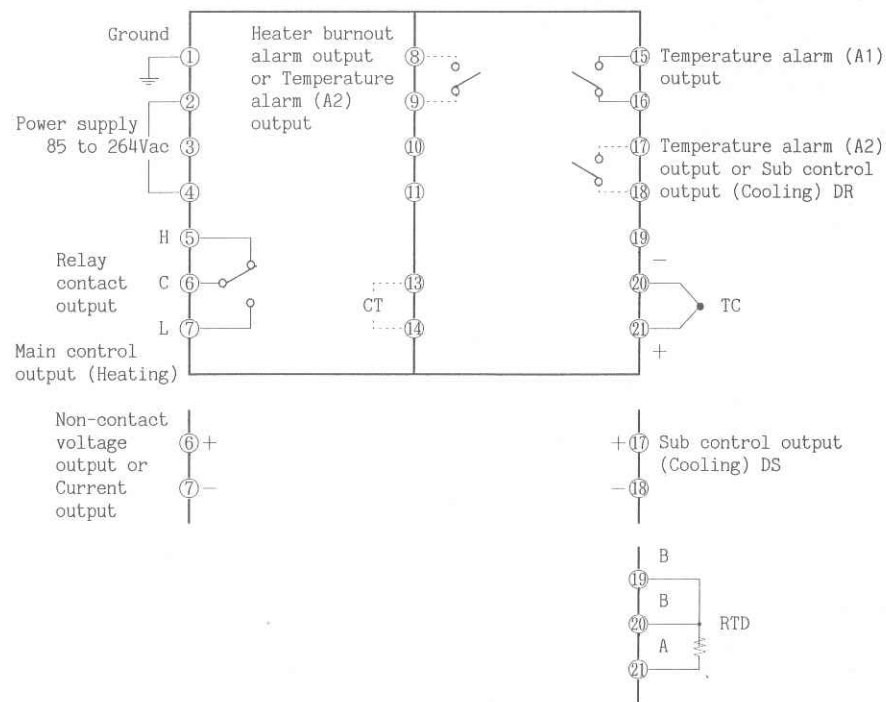

[Dotted line shows the option, no terminal is equipped if it is not specified.]

Terminal use

- When applied the option only [A2], use the terminals ⑰-⑱.
- When applied the options [A2] and [W], use the terminals ⑰-⑱ for [A2], and ⑧-⑨ for [W].
- When applied the options [D] and [A2], use the terminals ⑰-⑱ for [D], and ⑧-⑨ for [A2].

Notices

- Use a thermocouple and compensating lead wire applicable to the input specifications (K, J) of this controller.
- Use a 3-wire system of RTD applicable to the input specifications (Pt100, JPt100) of this controller.
- Check the specified voltage indicated on the voltage nameplate.
- This controller has no built-in power switch nor fuse. It is therefore recommended that these unit be provided in the circuit near the external controller.
- With relay output type of controller, it is recommended to provide the applicable relay to protect the built-in relay contact.
- When wiring, keep input wire (Thermocouple, RTD, etc.) away from AC source and load wire to avoid external interference.

[Option W: Heater burnout alarm function]

- This alarm is not available for detecting current under phase control.
- When using Current transformer (CT), select an accessory one.
- Pass a lead wire of heater circuit into the hole of the CT.
- When wiring, keep CT wire away from AC source and load wire.

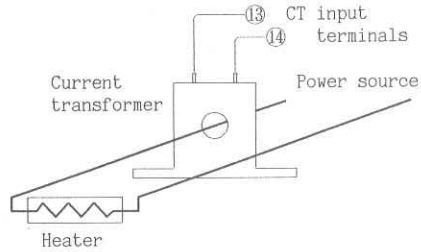

• Recommended terminal

Use a solderless terminal with insulation sleeve to fit to M3 screw as shown below.
Tightening torque: 0.6N·m to 1.0N·m

Solderless terminal	Manufacture	Model name	Tightening torque
Y type	Nichifu Terminal Industries CO.,LTD.	1.25Y-3	0.6N·m
	Japan Solderless Terminal MFG CO.,LTD.	VD1.25-B3A	
Round type	Nichifu Terminal Industries CO.,LTD.	1.25-3	Max. 1.0N·m
	Japan Solderless Terminal MFG CO.,LTD.	V1.25-3	

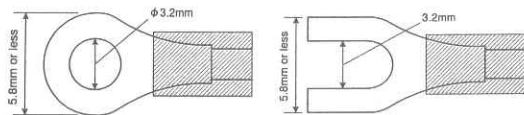

9.2 Wiring connection examples

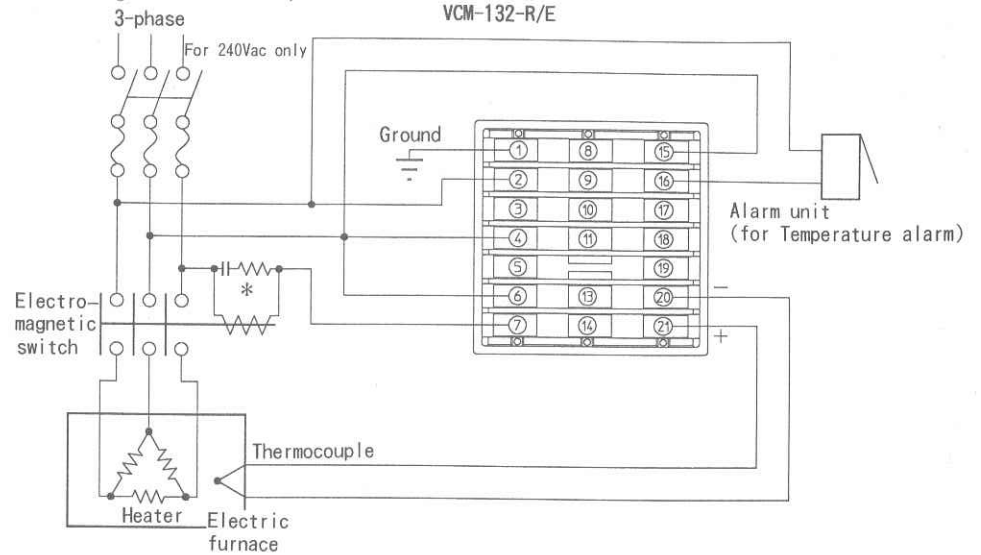

* To prevent the instrument from a bad influence owing to the unexpected level noise, it is recommended that the surge absorber be provided between the coil of the external relay.

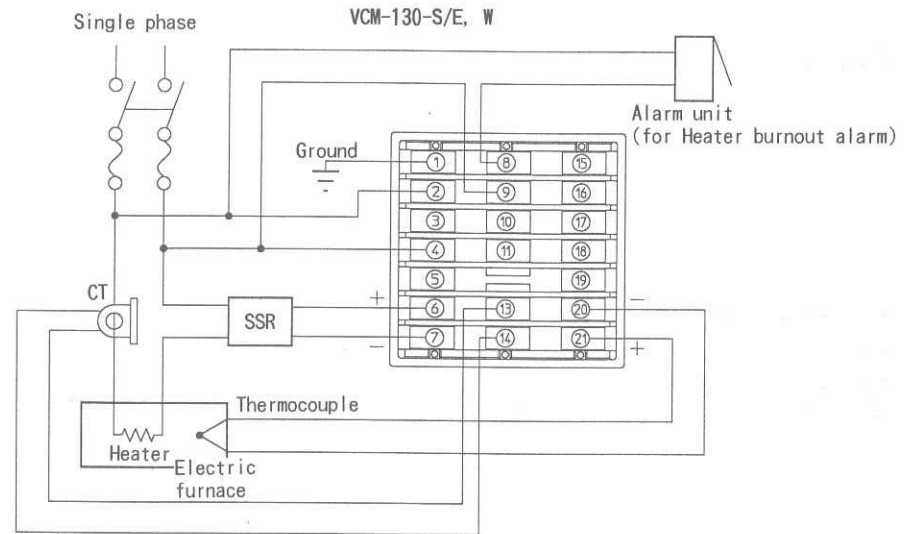

- Connectable SSRs in parallel are 4 units, if the Shinko SSRs (SA-200 series) are used.
- The terminal block of this instrument is designed to wire from the left side. Lead wire must be inserted from the left side of the terminal, and fasten by terminal screw with proper tool.

10. Specifications

10.1 Standard specifications

Mounting system	: Flush
Setting	: Input system using membrane sheet key
Display	
PV display	: Red LED, 3 digits, Size 14.3(H)×8(W)mm
SV display	: Green LED, 3 digits, Size 10(H)×5.5(W)mm
Accuracy	
Thermocouple	: Within $\pm 0.3\%$ of scaling span ± 1 digit, or $\pm 2^\circ\text{C}$ ($\pm 4^\circ\text{F}$) [Whichever is greater]
RTD	: Within $\pm 0.3\%$ of scaling span ± 1 digit, or $\pm 1^\circ\text{C}$ ($\pm 2^\circ\text{F}$) [Whichever is greater]
Rated scale	
Thermocouple	: K 0 to 400°C, 0 to 800°C, 0 to 999°C (0 to 800°F, 0 to 999°F) J 0 to 400°C, 0 to 800°C (0 to 800°F, 0 to 999°F)
RTD	: Pt100, JPt100 -19.9 to 99.9°C (-19.9 to 99.9°F), -199 to 400°C (-199 to 999°F)
Input	
Thermocouple	: K, J (100Ω or less)
RTD	: Pt100, JPt100, 3-wire system (resistance per wire 4Ω or less)
Output	
Relay contact	: 1c, capacity, 220Vac 3A (resistive load) 220Vac 1A (inductive load $\cos\phi=0.4$)
Non-contact voltage:	For SSR drive 15±3Vdc (load resistance 1.5kΩ), 20mA (short-circuit protected)
Current	: 4 to 20mAdc (isolated type) (load resistance max. 600Ω)
Temperature alarm output	: Relay contact, 1a Capacity, 220Vac 0.5A (resistive load) 220Vac 0.2A (inductive load $\cos\phi=0.4$)
Control action	: Main control action, PID action (with auto-tuning function) Proportional band 0.1 to 99.9% (acts ON/OFF when set to 0.0) Integral time 1 to 999s (off when set to 0) Derivative time 1 to 999s (off when set to 0) Anti-reset windup 0 to 100% Proportional cycle 1 to 120s
Temperature alarm	: ON/OFF action, Hysteresis 1°C (°F)
Supply voltage	: 100 to 240Vac, 50/60Hz
Allowable voltage fluctuation range	: 85 to 264Vac

Ambient temperature	: 0 to 50°C (32 to 122°F)
Ambient humidity	: 35 to 85%RH (non-condensing)
Power consumption	: Approx. 2.2W
Insulation resistance:	10MΩ or greater at 500Vdc (However, the voltage must not be applied to the terminals for Current transformer input, Non-contact voltage output and Current output.)
Dielectric strength	: Between Input terminal and Power terminal 500Vac for 1min. Between Input terminal and Ground terminal 500Vac for 1min. Between Power terminal and Ground terminal 1.5kVac for 1min. Between Output terminal and Power terminal 1.5kVac for 1min. (*) Between Output terminal and Ground terminal 1.5kVac for 1min. (*)
	(*) With the types, Non-contact voltage output and Current output type, the testing voltage must not be applied.
Weight	: Approx. 250 g
External dimension	: 72×72×85mm (W×H×D)
Case	: Polycarbonate resin, Color: Light gray
Attached functions	: • Scaling function (Scaling high limit and low limit setting) • Output limit function • Sensor correcting function • Setting value lock function • Power failure compensation (Data back-up by non-volatile IC memory) • Self-diagnostic function • Automatic cold junction temperature compensation (Thermocouple input) • Sensor burnout alarm [upscale] (Thermocouple input) • Control output OFF function
Accessories	: Mounting brackets 1 set Instruction manual 1 copy Current transformer, Model CTL-6-S 1 set [for 5A, 10A, 20A] Model CTL-11-TE 1 set [for 50A] or Model CTL-12-S36-10L1 1 set [for 50A]

10.2 Optional specifications

- [H] Temperature alarm (A1) output with standby function
The standby function is applicable to the types High limit, Low limit and High/Low limits alarm.
- [AL□] Temperature alarm (A2) output
The same temperature alarm besides the standard one. Designation of the action is followed AL the same as standard specification number.
Example: AL2, Temperature alarm (A2) High limit alarm
In case the option AL[] is applied, the options D[] and W are not available together, select only one option out of them.
- [AL□H] Temperature alarm (A2) output with standby function
Applied the standby function to the temperature alarm (A2) output, High limit Low limit and High/Low limits, [AL2H, AL3H and AL4H].
- [W] Heater burnout alarm output
In case the option W is applied, the options D[] and AL[] are not available together, select only one option out of them.
This option is not applicable to the type Current output.
Range : 1 to 100% (Setting the value to 0 disables the function.)
(current 5A, 10A or 20A, specified)
Setting accuracy: $\pm 5\%$
Action : ON/OFF action (Once alarm action operates, the output is held until the instrument power is turned off.)
Output : Relay contact, 1a
Capacity, 220Vac 0.5A (resistive load)
220Vac 0.2A (inductive load $\cos\phi=0.4$)
- [D□] Heating/cooling control output
In case the option D[] is applied, the options W and AL[] are not available together, select only one option out of them.
Cooling (C2) Proportional band : 0.1 to 10 times as much as the Main (C1) Proportional band
Cooling (C2) Integral time : Follows the main control setting value.
Cooling (C2) Derivative time : Follows the main control setting value.
Cooling (C2) Proportional cycle: 1 to 120s
Overlap band and Dead band setting range : -10.0 to 10.0% of scaling span
- [DR] Relay contact : 1a
Capacity, 220Vac 3A (resistive load)
220Vac 1A (inductive load $\cos\phi=0.4$)
- [DS] Non-contact voltage: For SSR drive
 15 ± 3 Vdc (load resistance $1.5k\Omega$)
20mA (short circuit protected)

- [F] Function selection
Sensor selection : Thermocouple, selects K or J, when it is thermocouple input type
RTD, selects Pt100 or JPt100, when it is RTD input type
°C/°F change : Changes the temperature unit °C or °F.
Direct/Reverse selection: Selects the action direct (Cooling) or reverse (Heating).
Temperature alarm type selection : Selects one of the type, out of High limit, Low limit High/Low limits and standby function is applied to them, and High/Low limit range and Process value.
ON/OFF action hysteresis selection : In case of ON/OFF action, the hysteresis is settable in the range 0.1 to 10.0°C (0.1 to 20.0°F)
- [SK] Specified hysteresis
Setting range: 0.1 to 10.0°C (0.1 to 20.0°F)
- [CM] Cooling action
Output turns OFF in the range in which the input value is lower than the setting value, and ON in the range higher than that.
PID action (with auto-tuning function)
Proportional band 0.1 to 99.9% (acts ON/OFF when set to 0.0)
Integral time 1 to 999s (off when set to 0)
Derivative time 1 to 999s (off when set to 0)
Anti-reset windup 0 to 100%
Proportional cycle 1 to 120s
- [PD] PD action (with auto-reset function)
Proportional band 0.1 to 99.9% (acts ON/OFF when set to 0.0)
Derivative time 1 to 999s (off when set to 0)
Proportional cycle 1 to 120s
- [BK] Color black
Faceplate : Dark gray
Base and Case: Black
- [TC] Terminal cover
Electrical shock protecting terminal cover

11. When troubled

When troubled, refer to the following items after checking the power and the wiring.

 **Warning**

Turn the power supplied to the instrument OFF before wiring or checking. If working or touching the terminal on the power ON status, there is a possibility of Electric Shock which can cause severe injury or death.

Phenomenon, Instrument status, etc.	Presumed cause
SV display indicating [OFF].	<ul style="list-style-type: none"> Control output OFF function is working. Cancel the function. (See page 18)
Setting mode cannot be selected by pressing the (MODE) key.	<ul style="list-style-type: none"> During PID auto-tuning. (See page 19)
Setting is impossible. The (▲), (▼) keys are ineffective.	<ul style="list-style-type: none"> Setting value lock function [LCR] or [LC4] is designated. (See page 15) Check the values Scaling high limit and Scaling low limit setting. (See page 16)
Process variable does not rise.	<ul style="list-style-type: none"> Burnout or improper connection of thermocouple, compensation lead wire or RTD. The connection at input terminal is wrong. Heater is burnt out or improper connection. Trouble on electromagnetic switch, trigger, etc.
Process variable rises too much.	<ul style="list-style-type: none"> Improper mounting (insertion) of thermocouple or RTD. Reverse polarity of thermocouple or compensating lead wire. Improper specification of thermocouple or RTD (resistance).
Process variable is unstable.	<ul style="list-style-type: none"> Influence of inductive fault or noise. AC leaks into thermocouple or RTD circuit. Improper connection at input terminal.

* If happened unclear phenomenon other than above mentioned, make inquiries at our agency or your shop where purchased about the matters.

12. Character table (*: The character is not indicated if the option is not designated.)

Character	Description	Character	Description
$\bar{n}C-$	Warmup status	PdF *	Pt100 -199 to 999°F
ζ	Main setting mode	PJc *	JPt100 -19.9 to 99.9°C
P	Proportional band setting mode	PJF *	JPt100 -19.9 to 99.9°F
I	Integral time setting mode	Pdc *	Pt100 -19.9 to 99.9°C
d	Derivative time setting mode	PdF *	Pt100 -19.9 to 99.9°F
\bar{n}	Anti-reset windup (ARW) setting mode	ζH	Scaling high limit setting mode
c	Main control (C1) output proportional cycle setting mode	ζL	Scaling low limit setting mode
$c-b$ *	Sub control (C2) output proportional cycle setting mode	oFH	Output high limit setting mode
$P-b$ *	Sub control (C2) output proportional band setting mode	oFL	Output low limit setting mode
R	Temperature alarm (A1) setting mode	ζo	Sensor correction setting mode
\bar{R} *	Temperature alarm (A2) setting mode	$c\bar{n}$ *	Control type designating mode
d *	Overlap band or Dead band setting mode	HE *	Heating (reverse) action
b *	Heater burnout alarm setting mode	co *	Cooling (direct) action
oFF	Control output OFF status	$AL\bar{n}$ *	Temperature alarm (A1) action designating mode
Loc	Setting value lock designating mode	$AL\bar{r}$ *	Temperature alarm (A2) action designating mode
--	Setting value lock is not designated	-- *	No alarm action
LCR	All setting value lock	H *	High limit alarm action
$LC4$	Locks except main setting value	L *	Low limit alarm action
ζE *	Sensor designating mode	HL *	High/Low limits alarm action
$\bar{n}t$ *	K 0 to 999°C	$\bar{u}ld$ *	High/Low limit range alarm action
$\bar{n}tF$ *	K 0 to 999°F	$H\bar{u}$ *	High limit alarm action with standby function
$\bar{n}J$ *	J 0 to 800°C	$L\bar{u}$ *	Low limit alarm action with standby function
$\bar{n}JF$ *	J 0 to 999°F	$HL\bar{u}$ *	High/Low limits alarm action with standby function
PJ *	JPt100 -199 to 400°C	$Rb4$ *	Process value alarm action
PJF *	JPt100 -199 to 999°F	dFR *	Main control differential setting mode
Pd *	Pt100 -199 to 400°C	dFb *	Sub control differential setting mode
		---	Burnout status (Upscale)

Write your data down

(Initial)

(Initial)

4		0°C	Loc		Unlock
P		2.5%	4E		K or Pt100
l		200s	4H		Specified
d		50s	4L		Specified
n		50%	oFH		100%
c		R/□: 30s S/□: 3s	oFL		0%
c_b		R/□: 30s S/□: 3s	4o		0.0°C
P_b		1	cñ		Heating
R		0°C	RLñ		
R		0°C	RLñ		
d		0.0%	dFA		1.0°C
b		0%	dFb		1.0°C
oFF					

MEMO